

Outline

MIPS Pipelined Implementations

Outline

Unpipelined Implementation. (Diagram only.)

Pipelined MIPS Implementations: Hardware, notation, hazards.

Dependency Definitions.

Data Hazards: Definitions, stalling, bypassing.

Control Hazards: Squashing, one-cycle implementation.

Outline: (Covered in class but not yet in set.)

Operation of nonpipelined implementation, elegance and power of pipelined implementation. (See text.)

Computation of CPI for program executing a loop.

Very Simple MIPS Implementations

Minimum Hardware Multi-cycle Implementation

From EE 3755 (as offered by dmk).

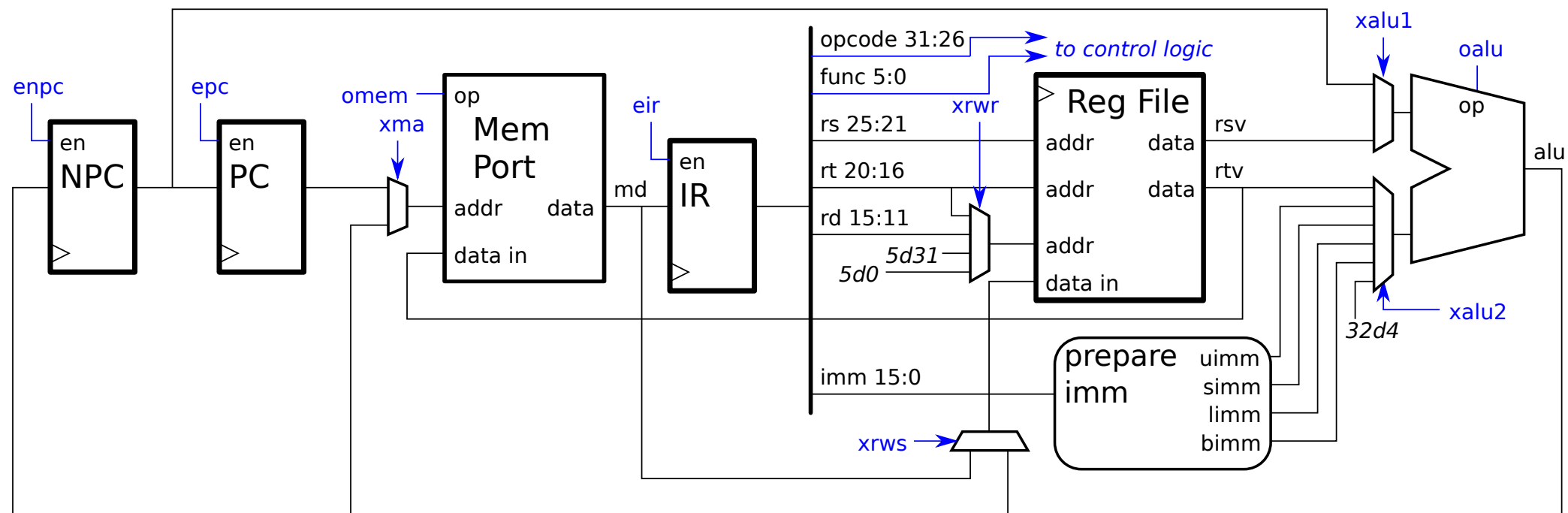

Features

Avoid duplication of hardware: One Memory Port, One Adder (ALU).

Relatively complex control logic needed to re-use ALU, etc.

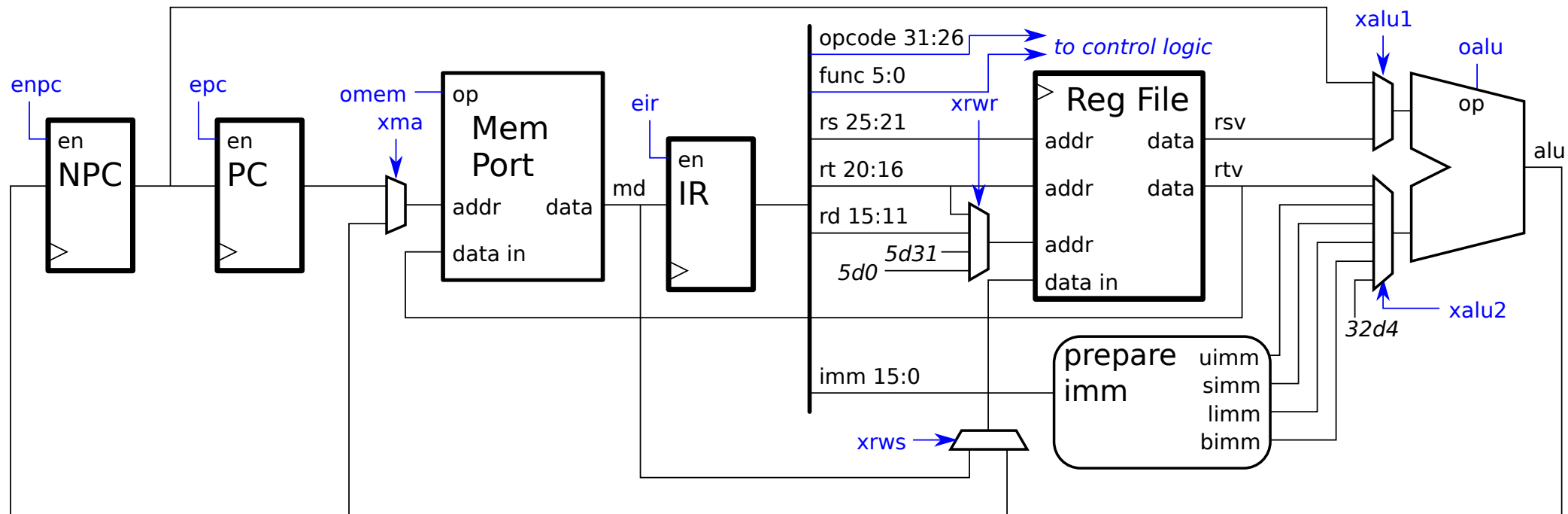

Unpipelined Implementation

In this implementation hardware *is* duplicated.

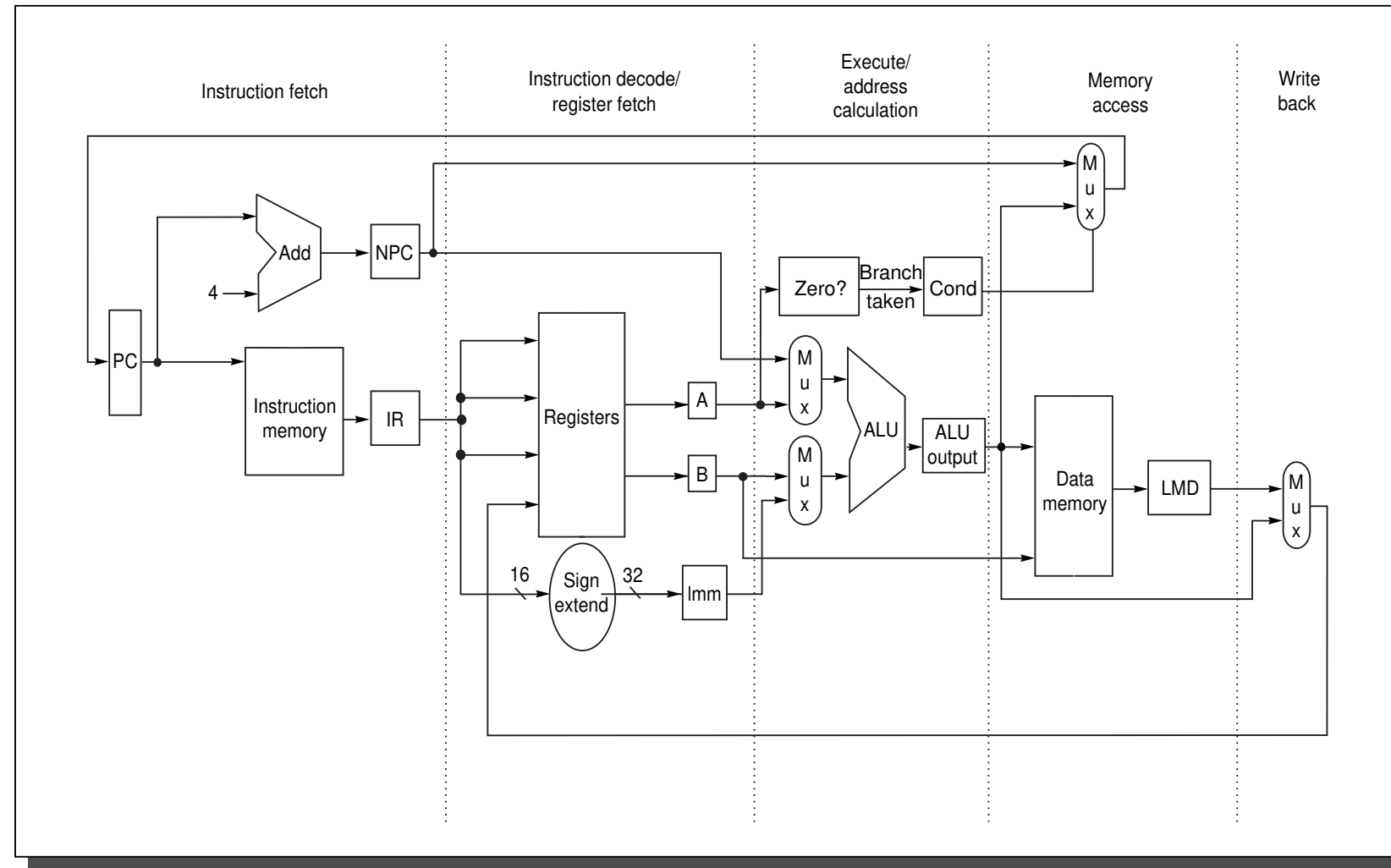
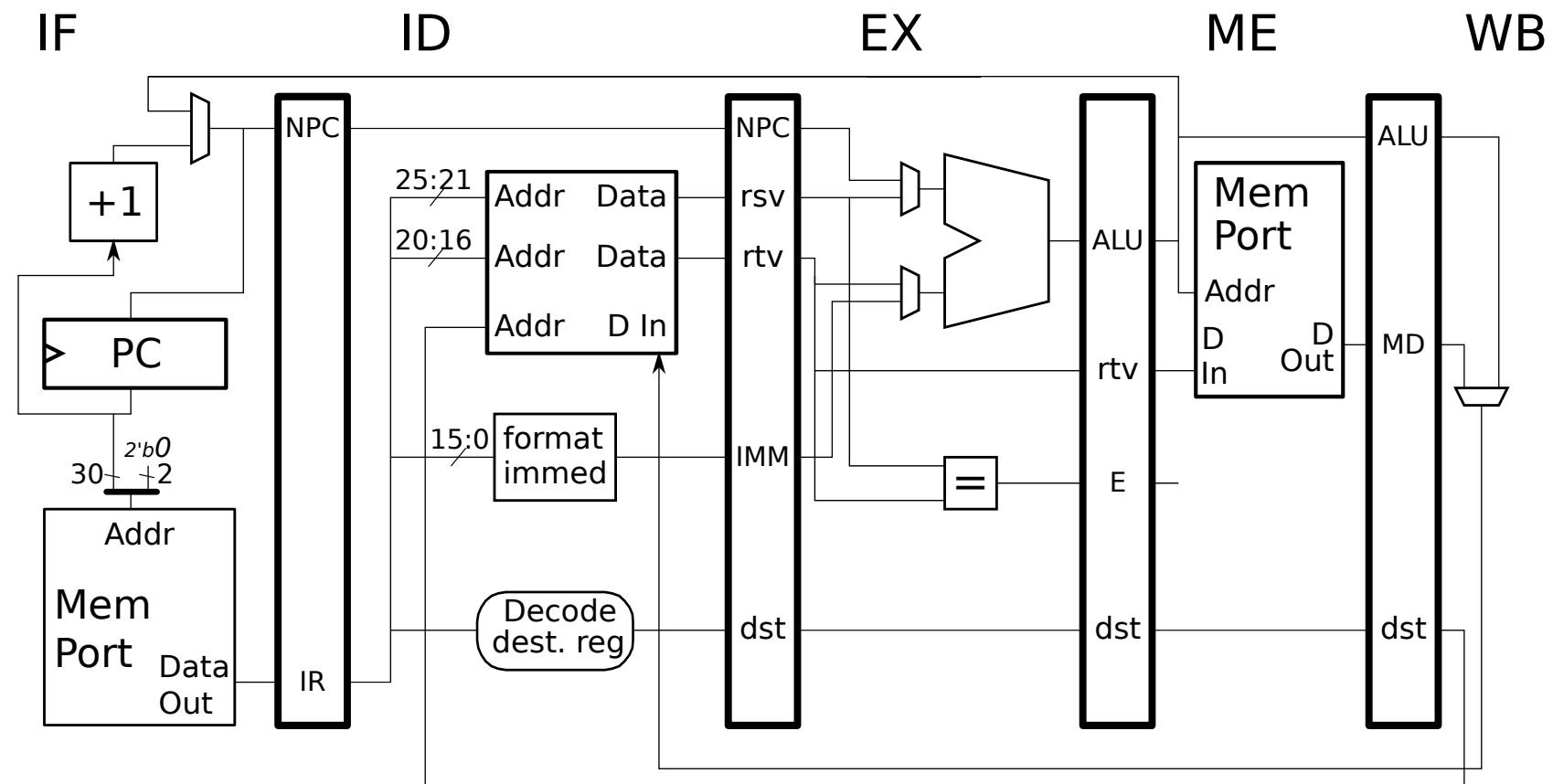

FIGURE 3.1 The implementation of the DLX datapath allows every instruction to be executed in four or five clock cycles.

Pipelining Terminology and Concepts

Pipelined MIPS Implementation



Pipelining Idea

Split hardware into n equally sized (in time) *stages* ...

... separate the stages using special registers called *pipeline latches* ...

... increase the clock frequency by $\approx n \times$...

... avoid problems due to overlapping of execution.

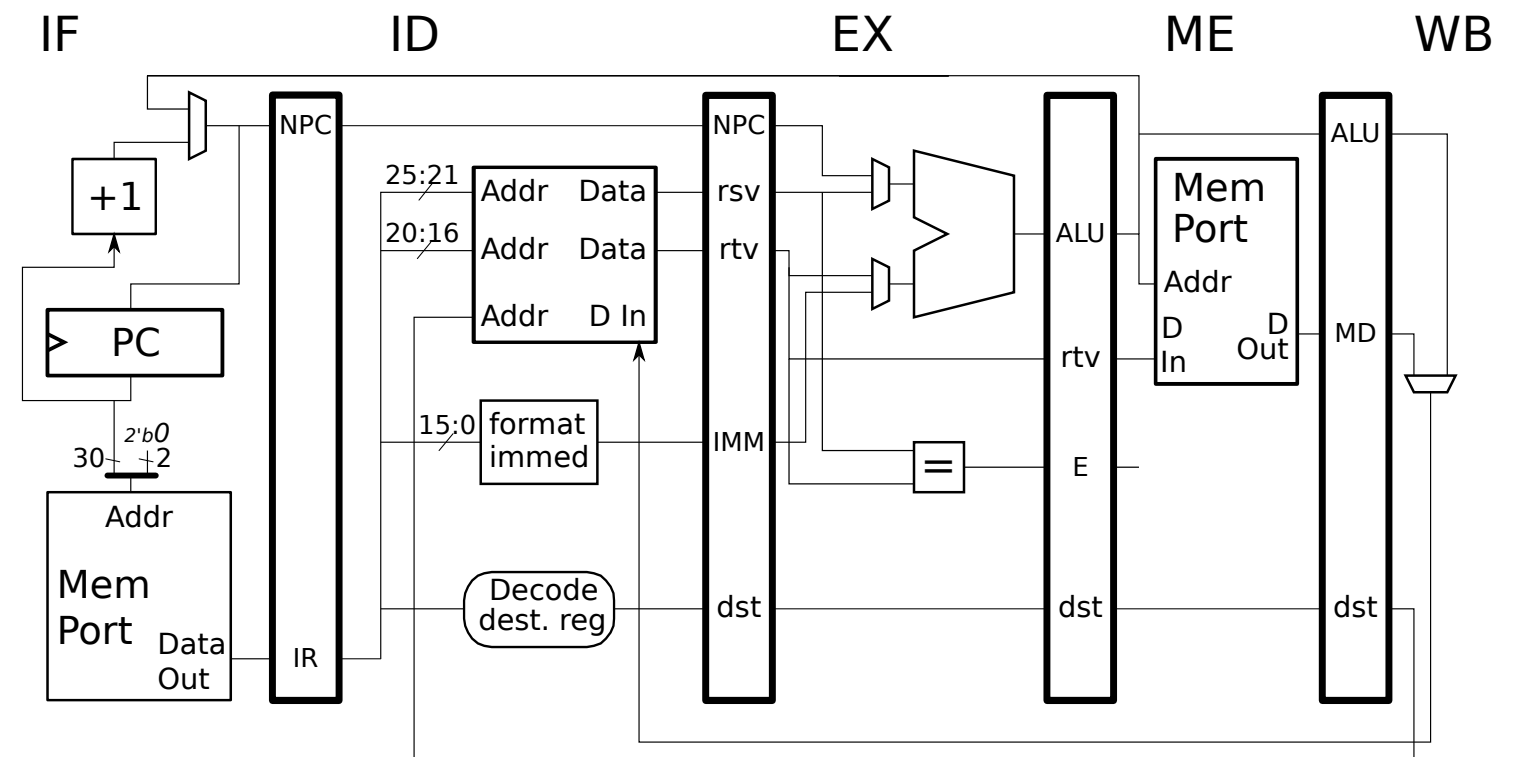

Pipeline Stages and Latches

Pipeline divided into *stages*.

Each stage occupied by at most one instruction.

At any time, each stage can be occupied by its own instruction.

Stages given names: IF, ID, EX, ME, WB

Sometimes ME written as MEM.

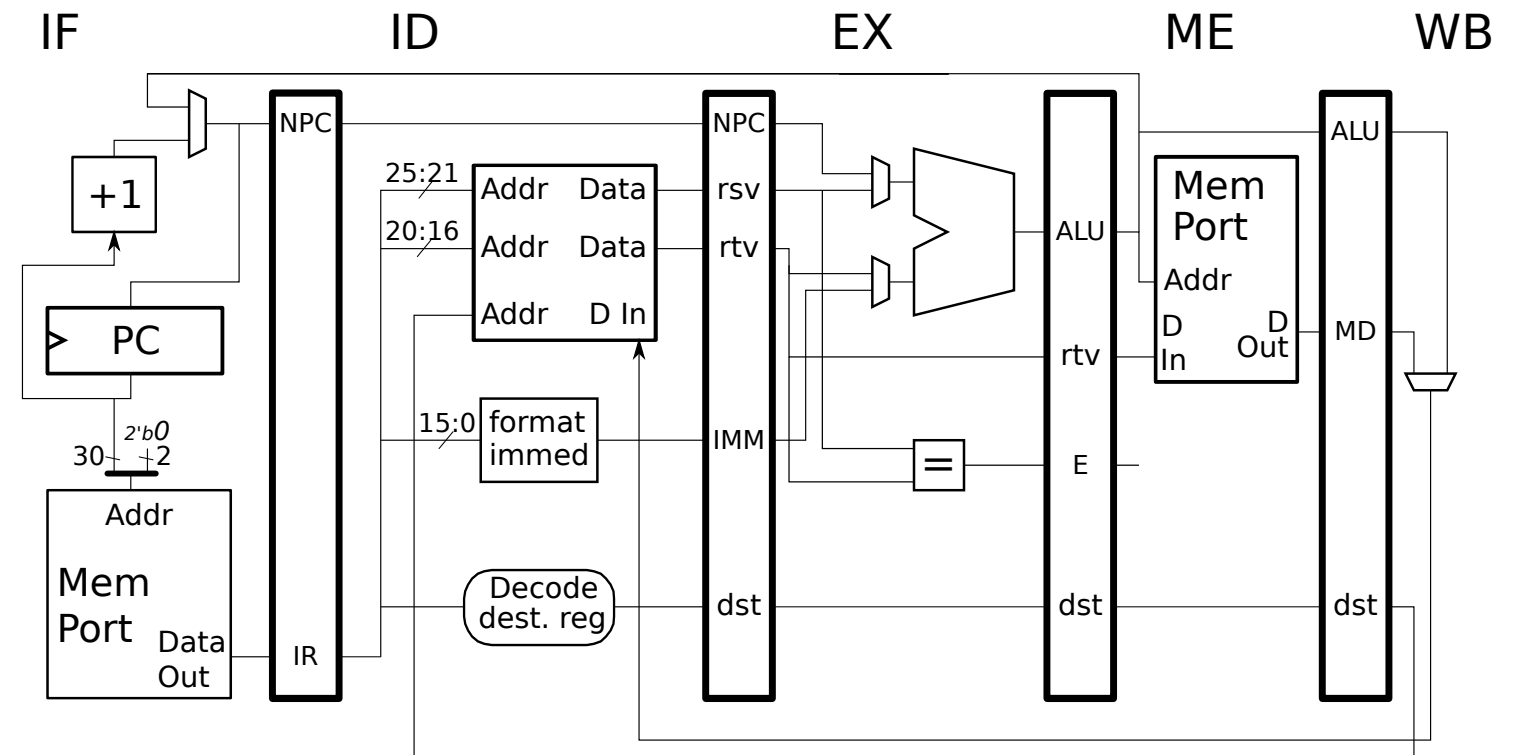

Pipeline Latches:

Registers separating pipeline stages.

Written at end of each cycle.

To emphasize role shown in diagram as bar separating stages.

Registers named using pair of stage names and register name.

For example, `IF/ID.IR`, `ID/EX.dst`, `ID/EX.rsv` (used in text, notes).

For brevity first stage name dropped: `ID.IR`, `EX.dst`, `EX.rsv`.

`if_id_ir`, `id_ex_ir`, `id_ex_rs_val` (used in Verilog code).

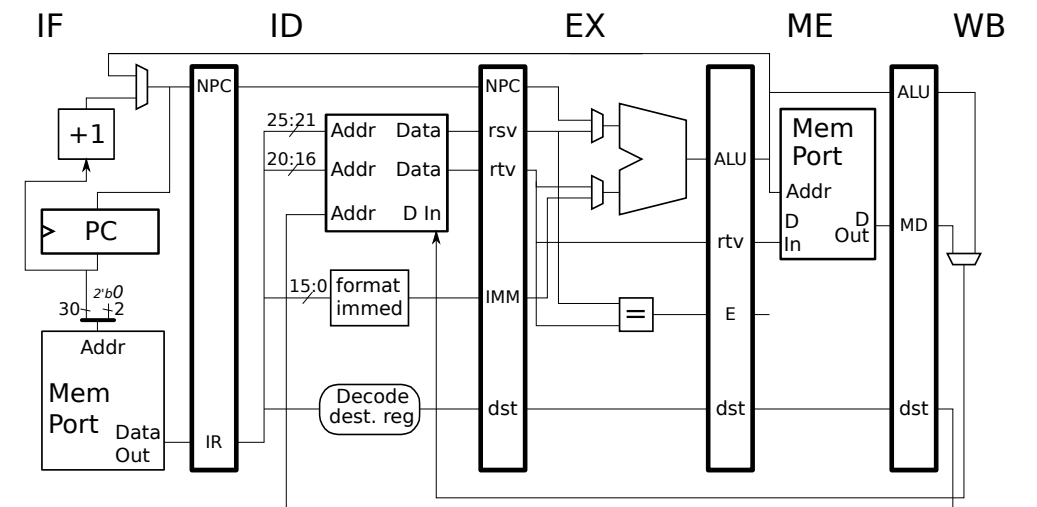

Pipeline Execution Diagram

Pipeline Execution Diagram:

Diagram showing the pipeline stages that instructions occupy as they execute.

Time on horizontal axis, instructions on vertical axis.

Diagram shows where instruction is at a particular time.

# Cycle	0	1	2	3	4	5	6
add r1, r2, r3	IF	ID	EX	ME	WB		
and r4, r5, r6		IF	ID	EX	ME	WB	
lw r7, 8(r9)			IF	ID	EX	ME	WB

A vertical slice (e.g. /, at cycle 3) shows processor activity at that time.

- ... if it appears more than once execution not correct ...
- ... since a stage can only execute one instruction at a time.

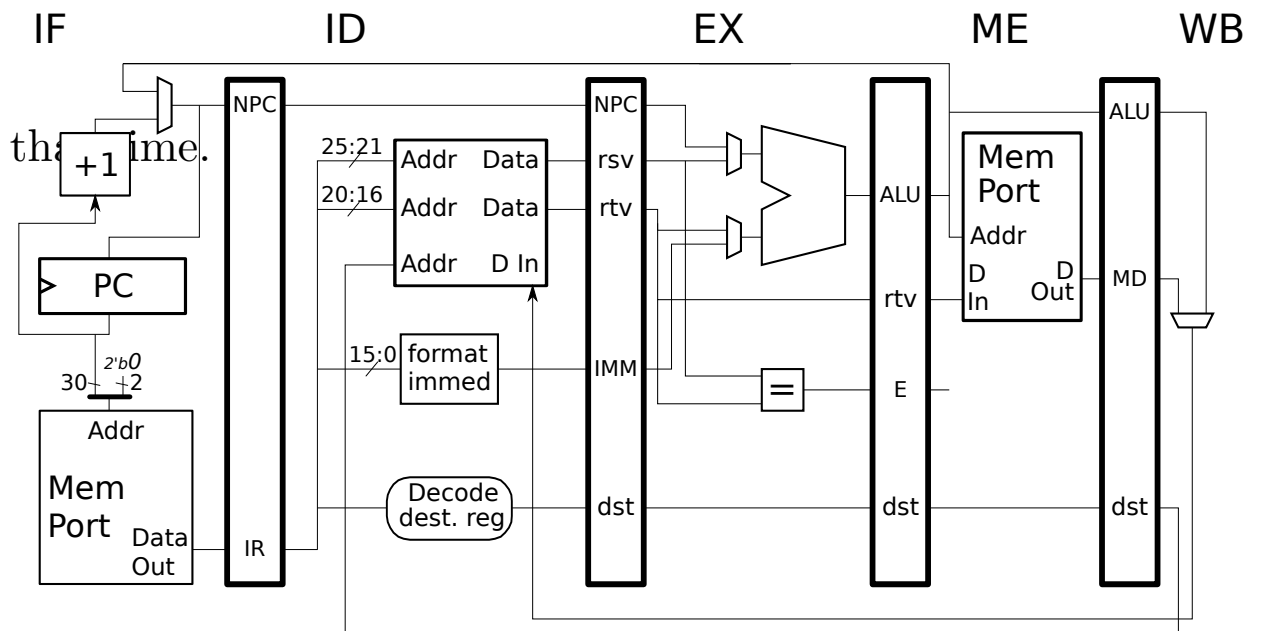

Instruction Decoding and Pipeline Control

Pipeline Control:

Setting control inputs to devices including ...

... multiplexor inputs ...

... function for ALU ...

... operation for memory ...

... whether to clock each register ...

... *et cetera*.

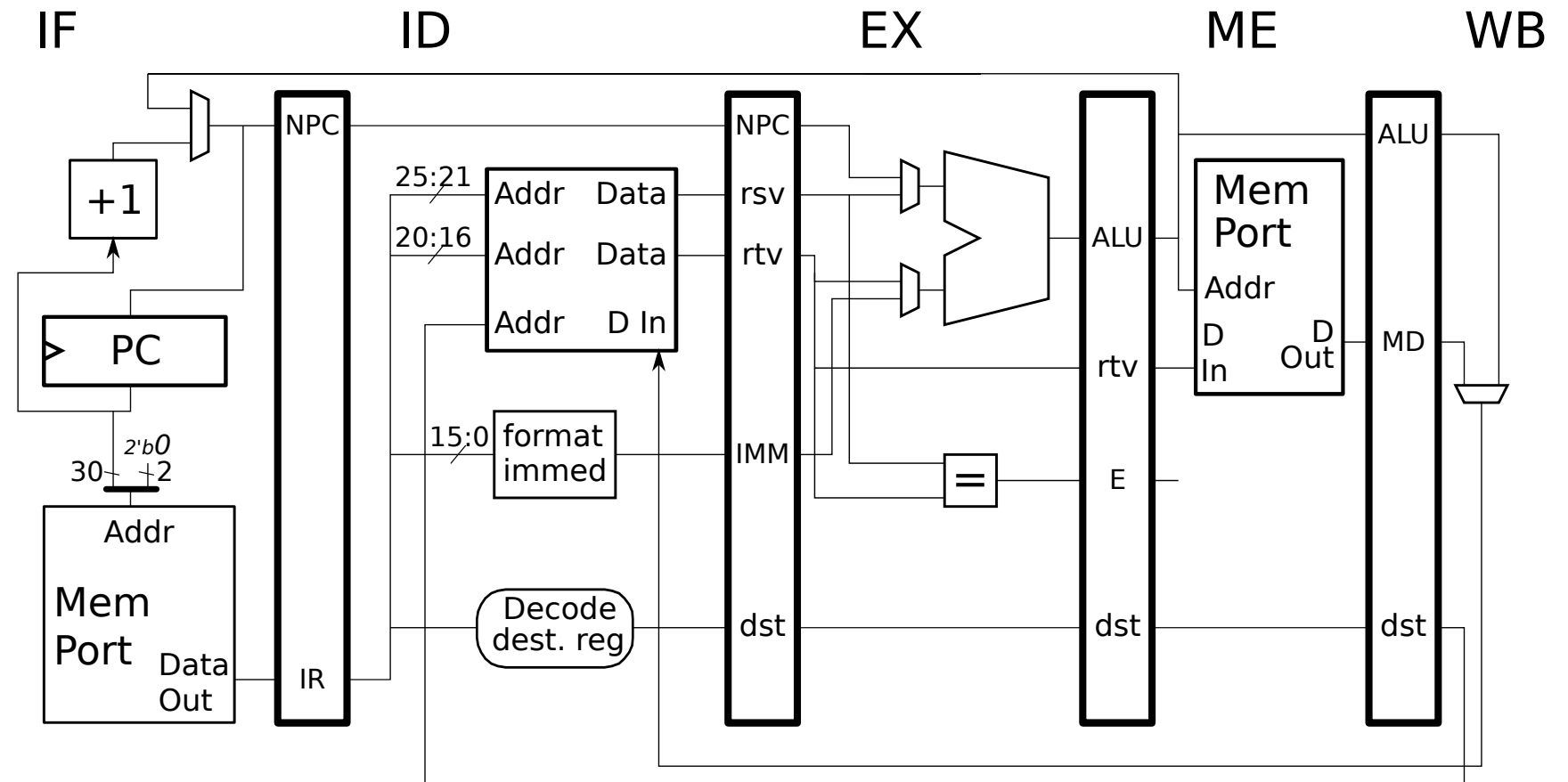

Options for controlling pipeline:

- Decode in ID
 - Determine settings in ID, pass settings along in pipeline latches.
- Decode in Each Stage
 - Pass opcode portions of instruction along.
 - Decoding performed as needed.

Many systems decode in ID.

Example given later in this set.

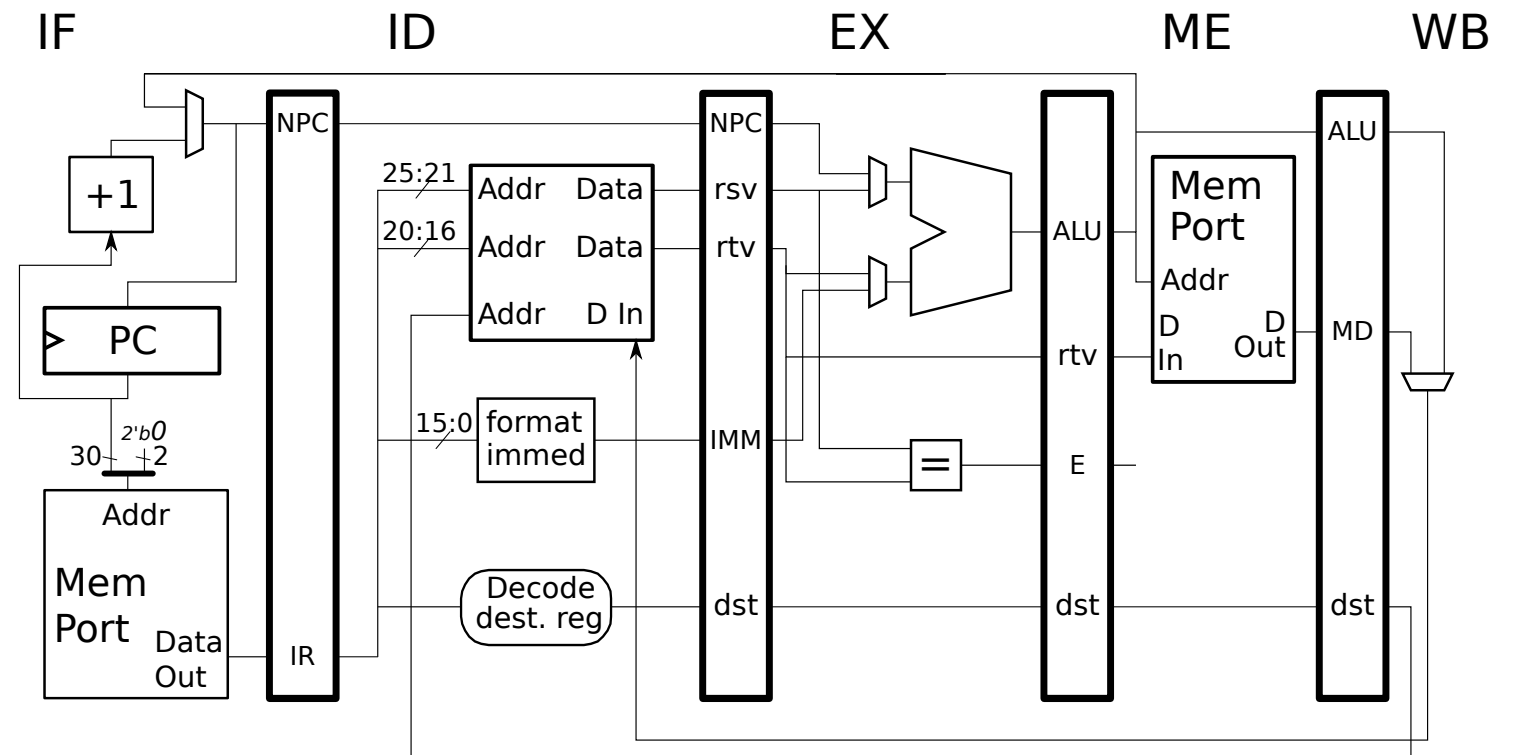

Dependencies and Hazards

Remember that sources **read from** registers in ID and results **written to** registers in WB.

Consider the following **incorrect execution**:

# Cycle		0	1	2	3	4	5	6	7
add	R1, r2, r3	IF	ID	EX	ME	WB			
sub	R4, R1, r5		IF	ID	EX	ME	WB		
and	r6, R1, r8			IF	ID	EX	ME	WB	
xor	r9, R4, r11				IF	ID	EX	ME	WB

Execution incorrect because ...

... **sub** reads **r1** before **add** writes (or even finishes computing) **r1**, ...

... **and** reads **r1** before **add** writes **r1**, and ...

... **xor** reads **r4** before **sub** writes **r4**.

Dependencies and Hazards

# Cycle	0	1	2	3	4	5	6	7
add R1, r2, r3	IF	ID	EX	ME	WB			
sub R4, R1, r5		IF	ID	EX	ME	WB		
and r6, R1, r8			IF	ID	EX	ME	WB	
xor r9, R4, r11				IF	ID	EX	ME	WB

Incorrect execution due to...

... *dependencies* in program...

... **and** *hazards* in hardware (pipeline).

Incorrect execution above is the “fault” of the hardware...

... because the ISA does not forbid dependencies.

Distinguishing Definitions

Dependency:

A relationship between two instructions ...

... indicating that their execution should be (or appear to be) in program order.

Hazard:

A potential execution problem in an implementation due to overlapping instruction execution.

There are several kinds of dependencies and hazards.

For each kind of dependence there is a corresponding kind of hazard.

Dependencies

Dependency:

A relationship between two instructions ...

... indicating that their execution should be, or appear to be, in program order.

If B is dependent on A then B should appear to execute *after* A .

Dependency Types:

- *True, Data, or Flow Dependence* (Three different terms used for the same concept.)
- *Anti Dependence*
- *Output Dependence*
- *Control Dependence*

Anti- and Output-Dependencies are both *Name Dependencies*.

Data Dependence

Data Dependence: (a.k.a., *True* and *Flow* Dependence)

A dependence between two instructions ...

... indicating data needed by the second is produced by the first.

Example:

```
add  R1, r2, r3
sub  R4, R1, r5
and  r6, R4, r7
```

The `sub` is dependent on `add` (via `r1`).

The `and` is dependent on `sub` (via `r4`).

The `and` is dependent `add` (via `sub`).

Execution may be *incorrect* if ...

... a program *having a data dependence* ...

... is run on a processor *having an uncorrected RAW hazard*.

Anti Dependence

Anti Dependence:

A dependence between two instructions ...
... indicating a value written by the second ...
... that the first instruction reads.

Antidependence Example

```
add  r1, R2, r3  
sub  R2, r4, r5
```

`sub` is antidependent on the `add`.

Execution may be incorrect if ...

... a program having an antidependence ...
... is run on a processor having an uncorrected WAR hazard.

Output Dependence

Output Dependence:

A dependence between two instructions ...

... indicating that both instructions write the same location ...

... (register or memory address).

Output Dependence Example

```
add  R1, r2, r3
sub  R1, r4, r5
```

The `sub` is output dependent on `add`.

Execution may be incorrect if ...

... a program having an output dependence ...

... is run on a processor having an uncorrected WAW hazard.

Control Dependence

Control Dependence:

A dependence between a branch instruction and a second instruction ...
... indicating that whether the second instruction executes ...
... depends on the outcome of the branch.

```
beq  $1, $0 SKIP    # Recall that branch has a delay slot.  
nop  
add  $2, $3, $4  
SKIP:  
sub  $5, $6, $7
```

The `add` is control dependent on the `beq`.

The `sub` is not control dependent on the `beq`.

Pipeline Hazards

Hazard:

A potential execution problem in an implementation due to overlapping instruction execution.

Interlock:

Hardware that avoids hazards by stalling certain instructions when necessary.

Hazard Types:

Structural Hazard:

Needed resource currently busy.

Data Hazard:

Needed value not yet available or overwritten.

Control Hazard:

Needed instruction not yet available or wrong instruction executing.

Data Hazards

Identified by acronym indicating correct operation.

- *RAW*: Read after write, akin to data dependency.
- *WAR*: Write after read, akin to anti dependency.
- *WAW*: Write after write, akin to output dependency.

MIPS implementations above only subject to RAW hazards.

RAR not a hazard since read order irrelevant (without an intervening write).

Stalls

When threatened by a hazard:

- *Stall* (Pause a part of the pipeline.)

Stalling avoids overlap that would cause error.

This does slow things down.

- Add hardware to avoid the hazards.

Details of hardware depend on hazard and pipeline.

Several will be covered.

Structural Hazards

Cause: two instructions simultaneously need one resource.

Solutions:

Stall.

Duplicate resource.

Pipelines in this section **do not** have structural hazards.

Covered in more detail with floating-point instructions.

Avoiding Data Hazards

Pipelined MIPS Subject to RAW Hazards.

Consider the following **incorrect execution** of code containing data dependencies.

# Cycle		0	1	2	3	4	5	6	7
add	R1, r2, r3	IF	ID	EX	ME	WB			
sub	R4, R1, r5		IF	ID	EX	ME	WB		
and	r6, R1, r8			IF	ID	EX	ME	WB	
xor	r9, R4, r11				IF	ID	EX	ME	WB

Execution incorrect because ...

... **sub** reads **r1** before **add** writes (or even finishes computing) **r1**, ...

... **and** reads **r1** before **add** writes **r1**, and ...

... **xor** reads **r4** before **sub** writes **r4**.

Problem fixed by *stalling* the pipeline.

Stall:

To pause execution in a pipeline from IF up to a certain stage.

With stalls, code can execute correctly:

For code on previous slide, stall until data in register.

# Cycle		0	1	2	3	4	5	6	7	8	9	10
add	R1, r2, r3	IF	ID	EX	ME	WB						
sub	R4, R1, r5		IF	ID	----->		EX	ME	WB			
and	r6, R1, r8			IF	----->		ID	EX	ME	WB		
xor	r9, R4, r11						IF	ID	->	EX	ME	WB

Arrow shows that instructions stalled.

Stall creates a *bubble*, stages without valid instructions, in the pipeline.

With bubbles present, CPI is greater than its ideal value of 1.

Stall Implementation

Stall implemented by asserting a *hold* signal ...

... which inserts a *nop* (or equivalent) after the stalling instruction ...

... and disables clocking of pipeline latches before the stalling instruction.

# Cycle	0	1	2	3	4	5	6	7	8	9	10
add R1, r2, r3	IF	ID	EX	ME	WB						
sub R4, R1, r5		IF	ID	----->		EX	ME	WB			
and r6, R1, r8			IF	----->		ID	EX	ME	WB		
xor r9, R4, r11						IF	ID	->	EX	ME	WB

During cycle 3, a *nop* is in EX.

During cycle 4, a *nop* is in EX and ME .

The two adjacent *nops* are called a *bubble* ...

... they move through the pipeline with the other instructions.

A third *nop* is in EX in cycle 7.

Bypassing

Some stalls are avoidable.

Consider again:

# Cycle		0	1	2	3	4	5	6	7	8	9	10
add	R1, r2, r3	IF	ID	EX	ME	WB						
sub	R4, R1, r5		IF	ID	EX	ME	WB					
and	r6, R1, r8			IF	ID	EX	ME	WB				
xor	r9, R4, r11				IF	ID	EX	ME	WB			

Note that the new value of **r1** needed by **sub** ...
 ... has been computed at the end of cycle 2 ...
 ... and isn't really needed until the beginning of the *next* cycle, 3.

Execution was incorrect because the value had to go around the pipeline to ID.

Why not provide a shortcut?

Why not call a shortcut a *bypass* or *forwarding* path?

Non-Bypassed MIPS

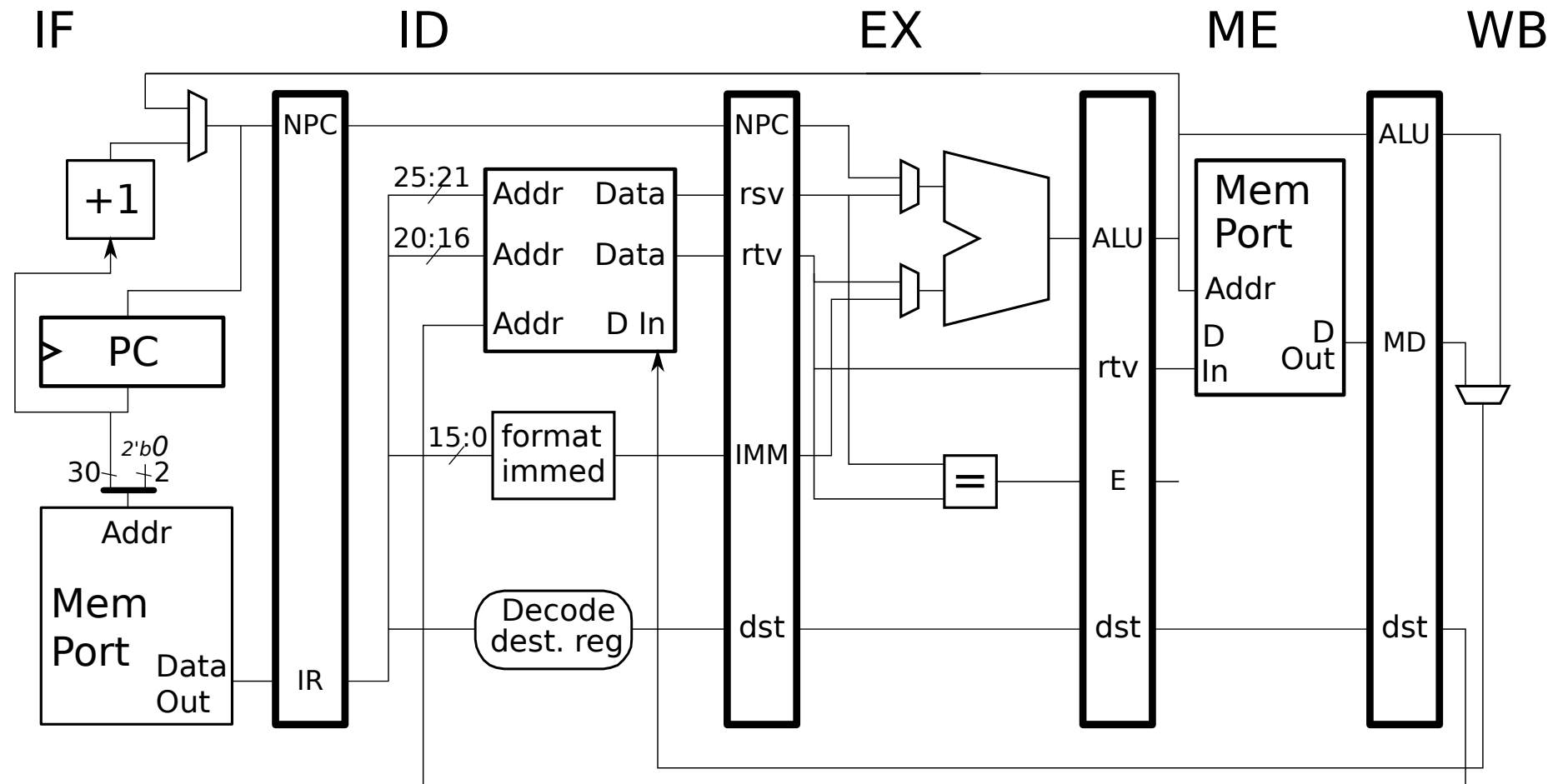

Bypassed MIPS

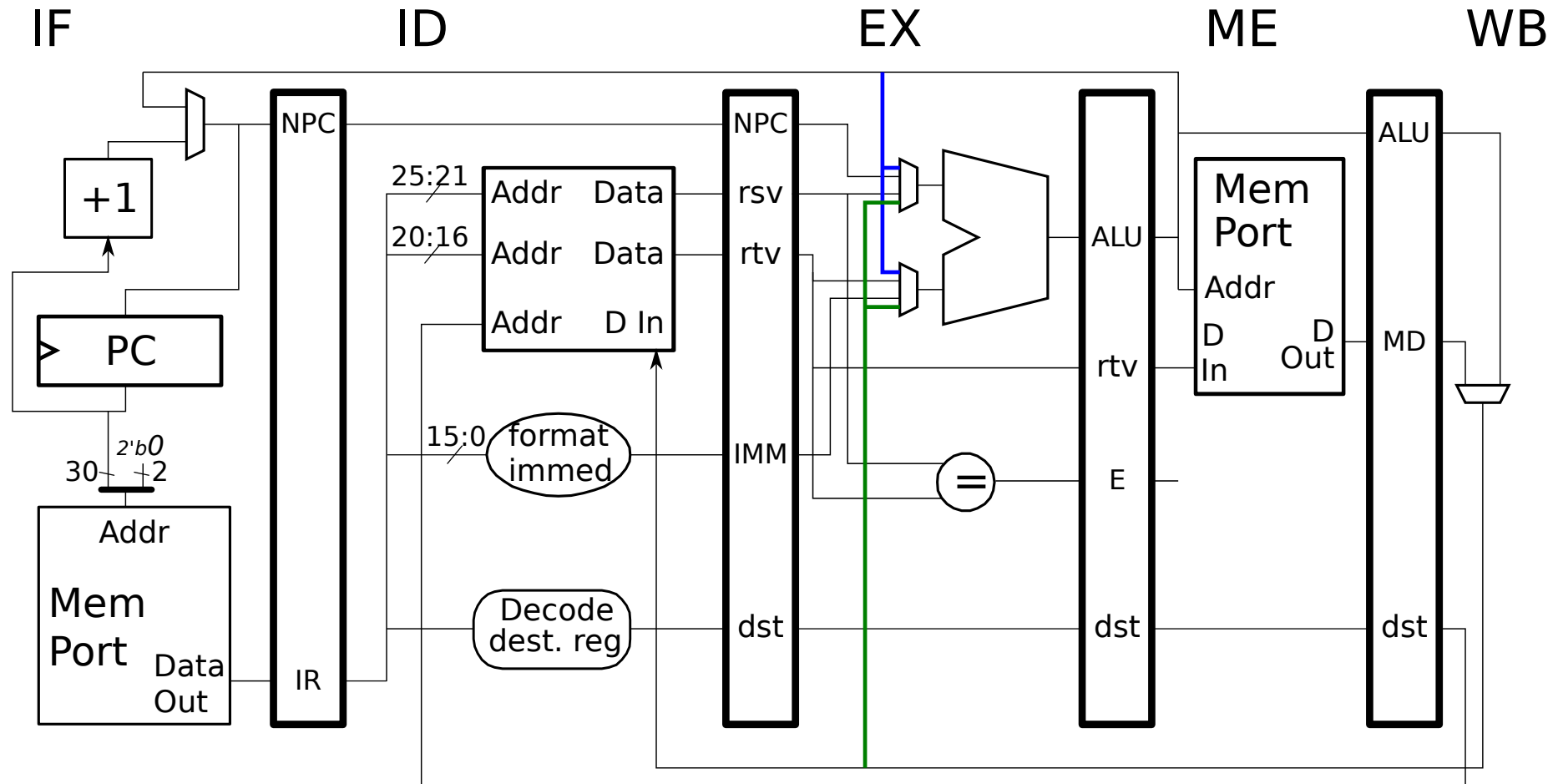

MIPS Implementation With Some Bypass Paths

# Cycle	0	1	2	3	4	5	6	7
add R1, r2, r3	IF	ID	EX	ME	WB			
sub R4, R1, r5		IF	ID	EX	ME	WB		
and r6, R1, r8			IF	ID	EX	ME	WB	
xor r9, R4, r11				IF	ID	EX	ME	WB

It works!

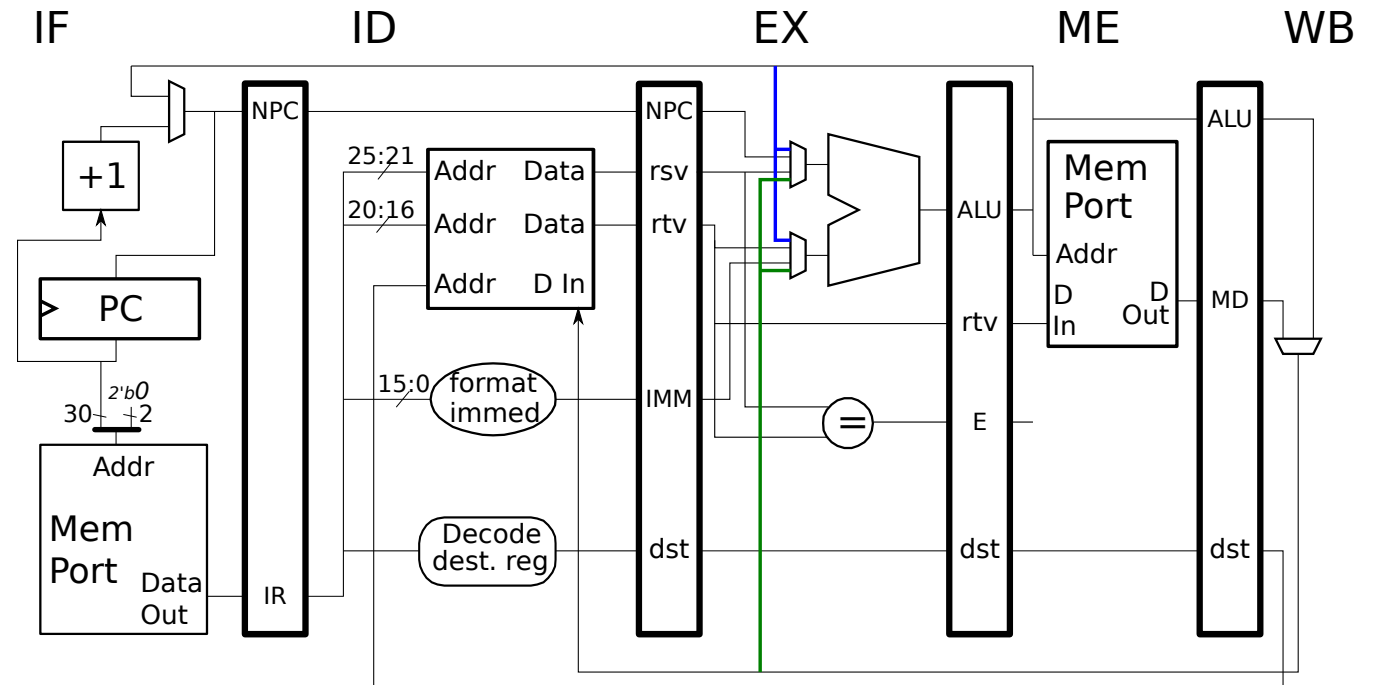

Some stalls unavoidable.

# Cycle	0	1	2	3	4	5	6	7	8	9	10
lw R1, 0(r2)	IF	ID	EX	ME	WB						
add R1, R1, r4		IF	ID	->	EX	ME	WB				
sw 4(r2), R1			IF	->	ID	----->	EX	ME	WB		
addi r2, r2, 8					IF	----->	ID	EX	ME	WB	

Stall due to `lw` could not be avoided with a bypass path (data not available in cycle 3).

Stall in cycles 5 and 6 could be avoided with a new bypass path.

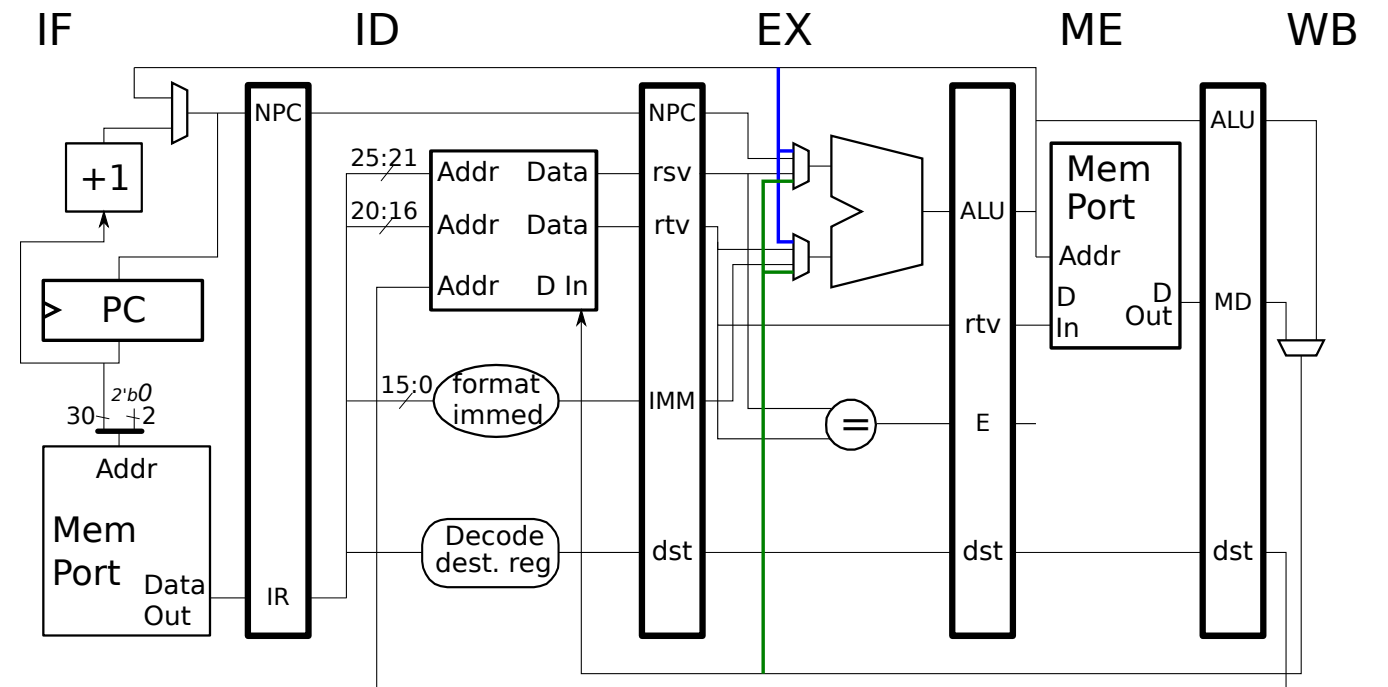

Control Logic Design Example(s)

In this part design logic to determine `dst` ...

... and using that the bypass control logic for lower ALU mux.

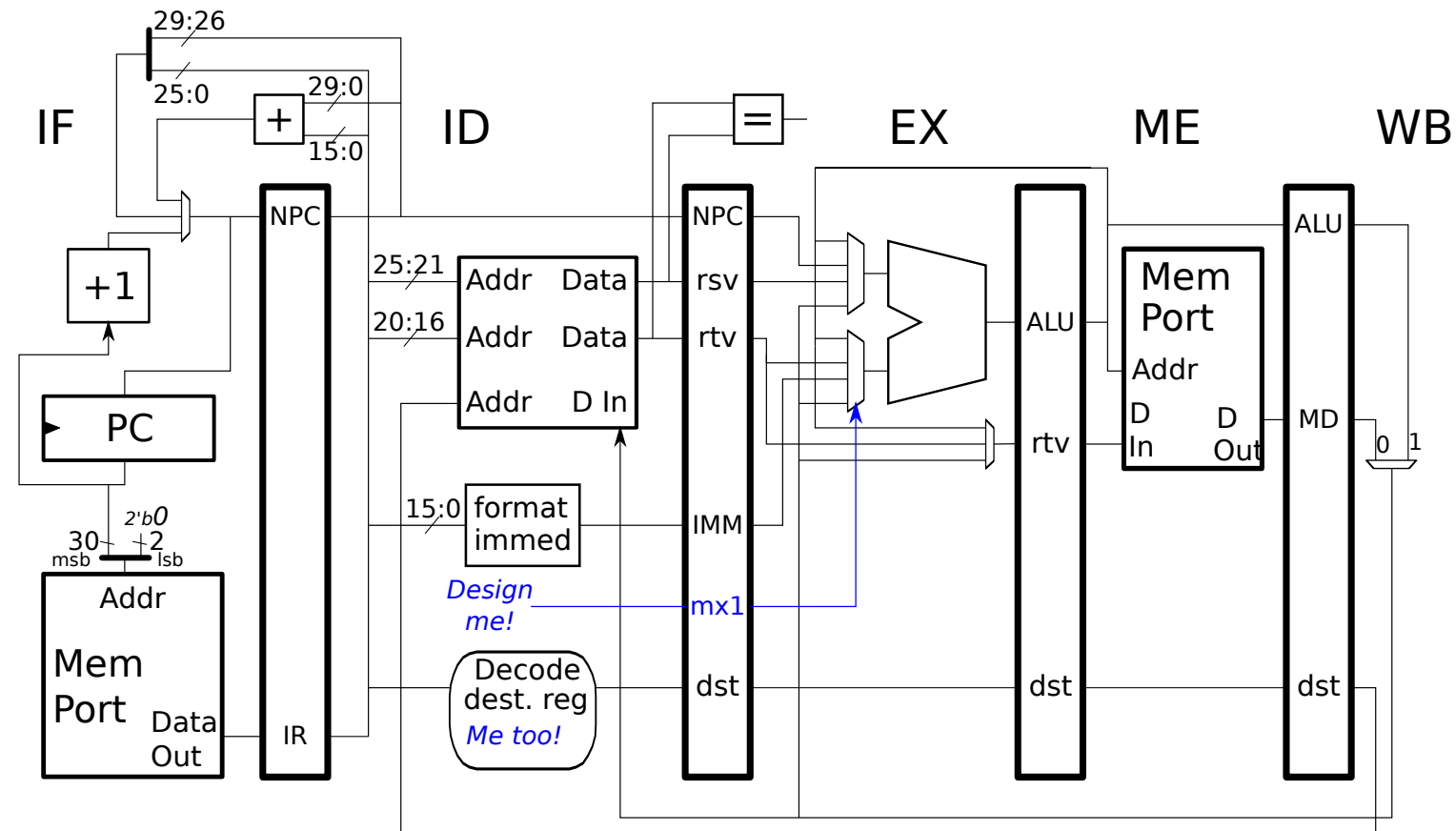

Logic to determine **dst** for register file.

Note: **dst** is the register that will be written ...
 ... or 0 if no register is written.

Depending on the instruction ...
 ... the value is in the **rd** or **rt** field ...
 ... or is the constant 0 or 31.

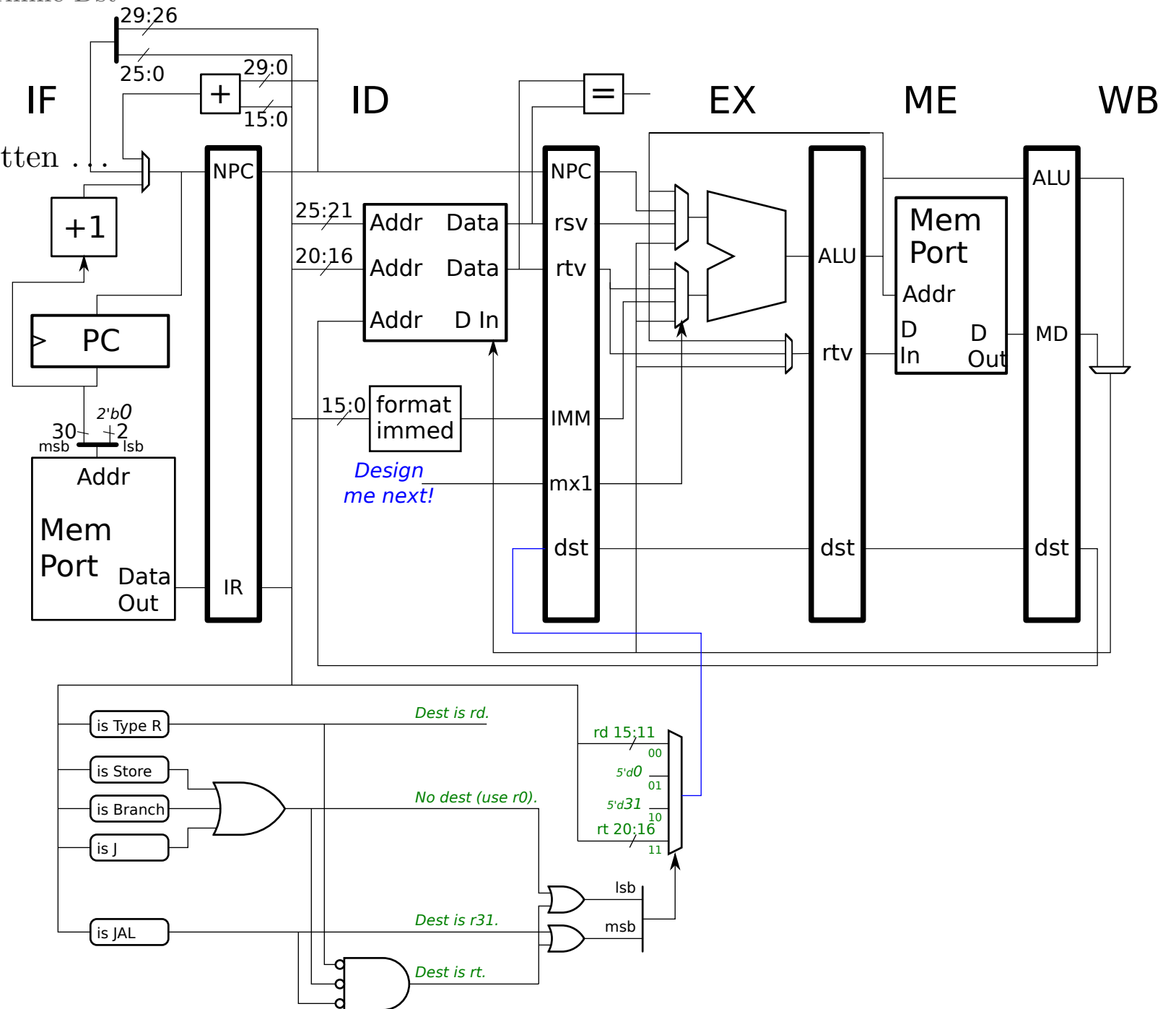

Bypass Control Logic for Lower ALU Mux

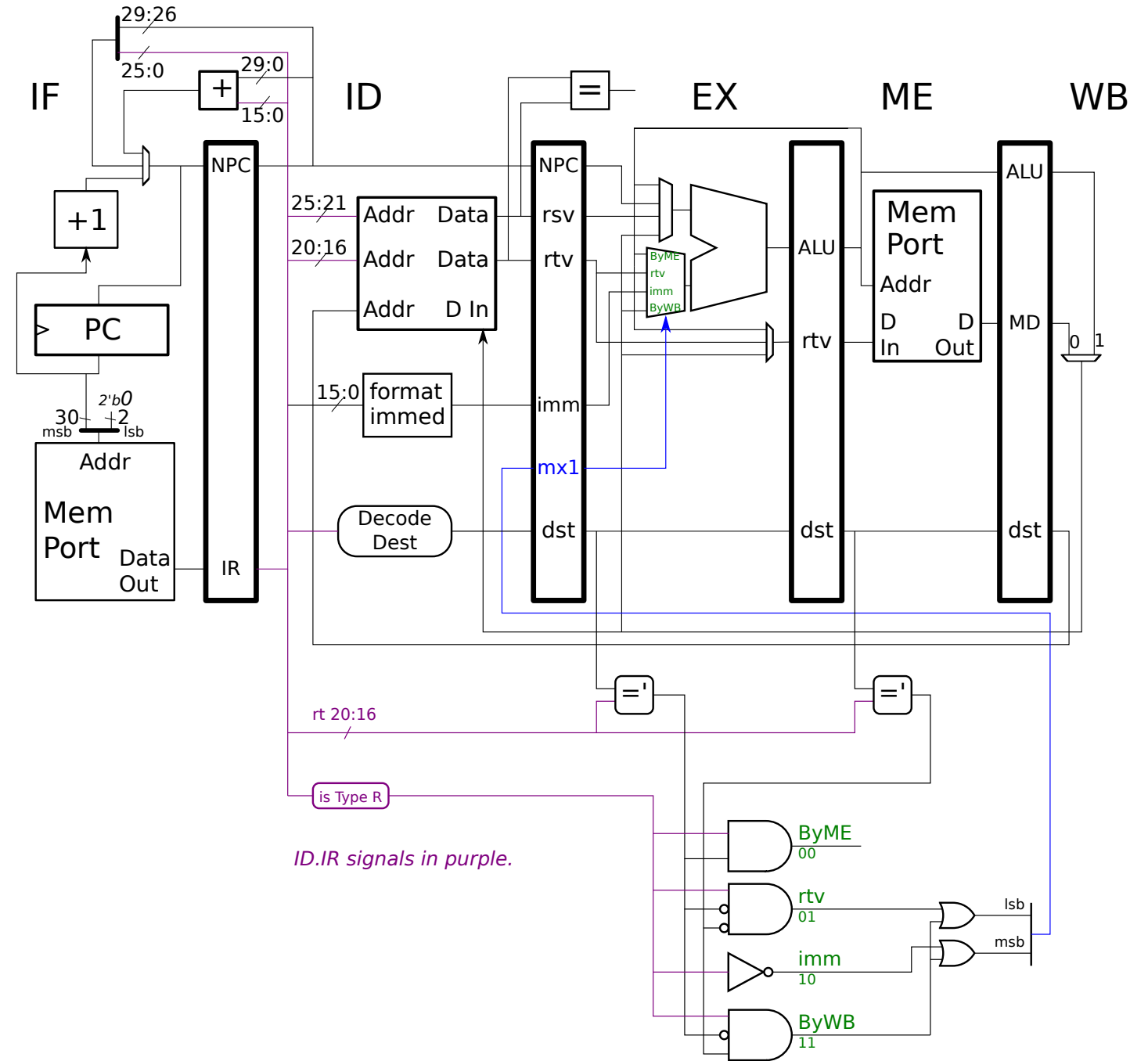

ID.IR signals in purple.

Notes about logic:

Control logic not minimized (for clarity).

Control Logic Generating `dst`.

Present in previous implementations, just not shown.

Determines which register gets written based on instruction.

Instruction categories used in boxes such as `= is Store` (some instructions omitted):

`= is Type R`: All Type R instructions.

`= is Store`: All store instructions.

`= is Branch`: branches such as `beq` and `bltz`.

`= is JAL`, `= is J`: Matches the exact instruction.

Logic Generating ID/EX.MUX.

$\boxed{=}$ box determines if two register numbers are equal.

Register number zero is not equal register zero, nor any other register.

(The bypassed zero value might not be zero.)

Branch Hardware

Consider:

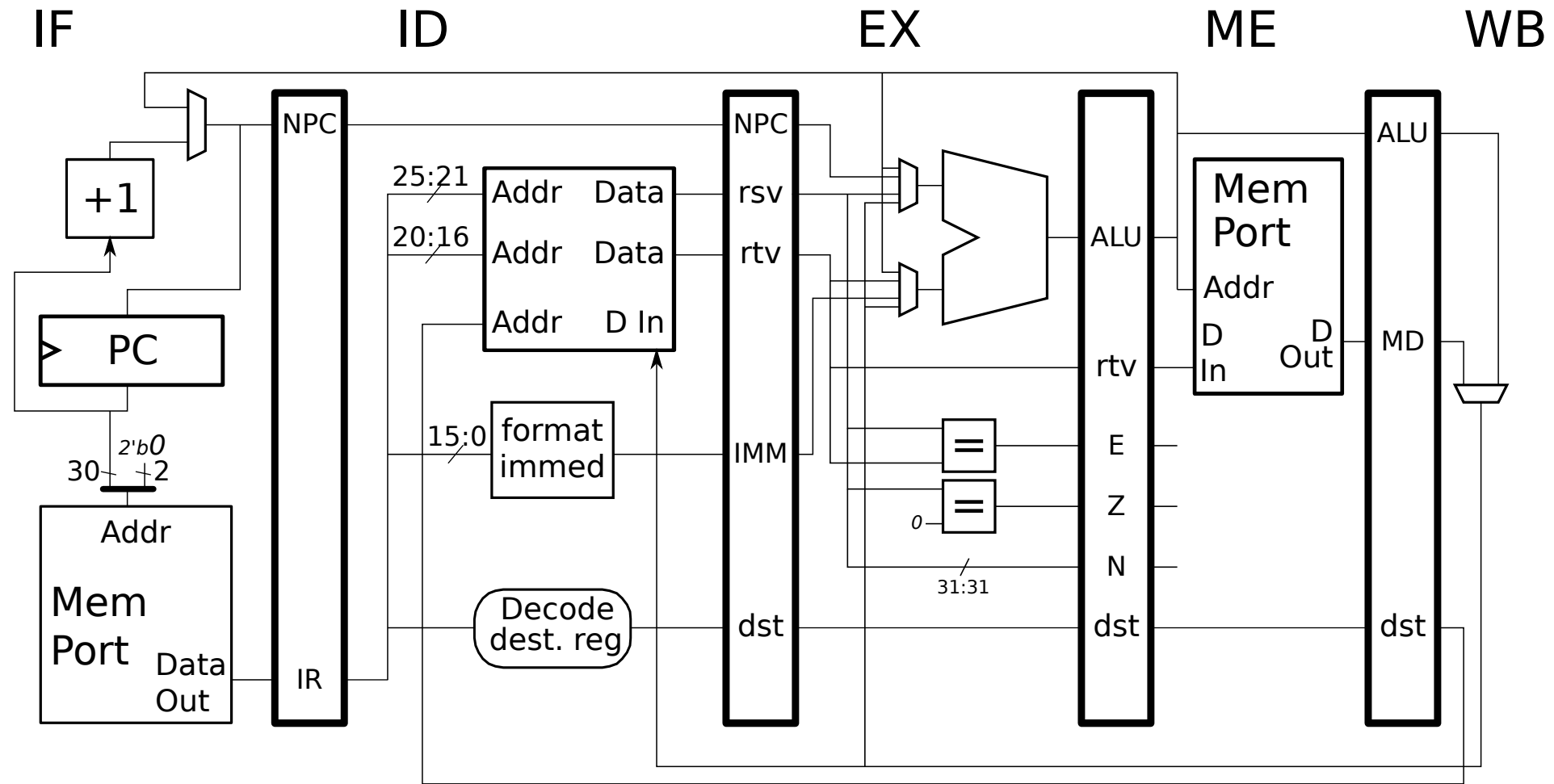

Example of incorrect execution

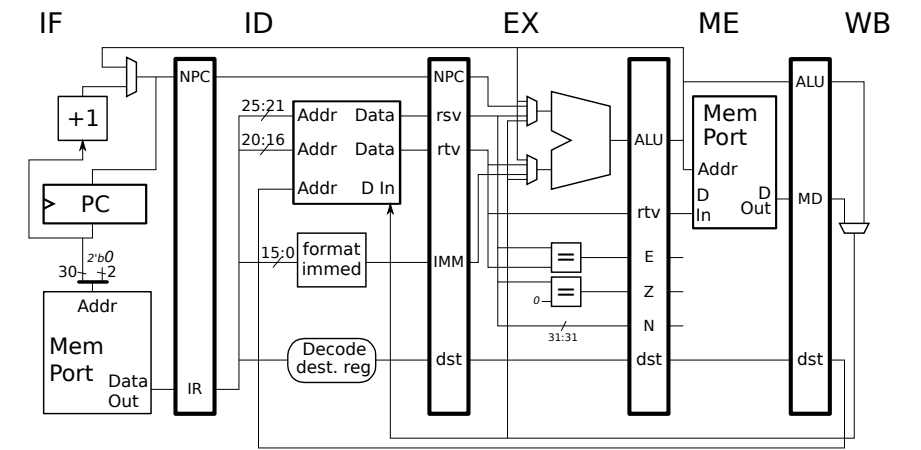

#I	Adr	Cycle	0	1	2	3	4	5	6	7	8
0x100	bgtz r4, TARGET	IF	ID	EX	ME	WB					
0x104	sub r4, r2, r5		IF	ID	EX	ME	WB				
0x108	sw 0(r2), r1			IF	ID	EX	ME	WB			
0x10c	and r6, r1, r8				IF	ID	EX	ME	WB		
0x110	or r12, r13, r14										
...											
TARGET: # TARGET = 0x200											
0x200	xor r9, r4, r11					IF	ID	EX	ME	WB	

Branch is taken yet two instructions past delay slot (**sub**) complete execution.

Branch target finally fetched in cycle 4.

Problem: Two instructions following delay slot.

Handling Instructions Following a Taken Branch Delay Slot

Option 1: Don't fetch them.

Possible (with pipelining) because ...

... fetch starts (`sw` in cycle 2) ...

... after branch decoded.

(Would be impossible ...

... for non-delayed branch.)

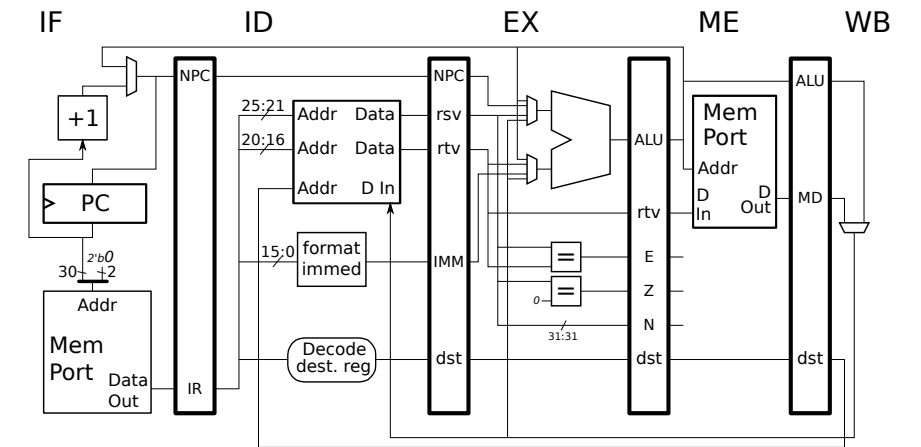

#I	Adr	Cycle	0	1	2	3	4	5	6	7	8
0x100	<code>bgtz r4, TARGET</code>	IF	ID	EX	ME	WB					
0x104	<code>sub r4, r2, r5</code>		IF	ID	EX	ME	WB				
0x108	<code>sw 0(r2), r1</code>			IF	ID	EX	ME	WB			
0x10c	<code>and r6, r1, r8</code>				IF	ID	EX	ME	WB		
0x110	<code>or r12, r13, r14</code>										
...											
TARGET: # TARGET = 0x200											
0x200	<code>xor r9, r4, r11</code>				IF	ID	EX	ME	WB		

Handling Instructions Following a Taken Branch

Option 2: Fetch them, but squash (stop) them in a later stage.

This will work if instructions squashed ...

... *before* modifying architecturally visible storage (registers and memory).

Memory modified in ME stage and registers modified in WB stage ...

... so instructions must be stopped before beginning of ME stage.

Can we do it? Depends depends where branch instruction is.

In example, need to squash `sw` before cycle 5.

During cycle 3 `bgtz` in ME ...

... it has been decoded and the branch condition is available ...

... so we know whether the branch is taken ...

... so `sw` can easily be squashed before cycle 5.

Option 2 will be used.

Instruction Squashing

In-Flight Instruction::

An instruction in the execution pipeline.

Later in the semester a more specific definition will be used.

Squashing:: [an instruction]

preventing an in-flight instruction ...

... from writing registers, memory or any other visible storage.

Squashing also called: *nulling*, *abandoning*, and *cancelling*..

Like an insect, a squashed instruction is still there (in most cases) but can do no harm.

Squashing Instruction in Example MIPS Implementation

Two ways to squash.

- Prevent it from writing architecturally visible storage.

Replace destination register control bits with zero. (Writing zero doesn't change anything.)

Set memory control bits (not shown so far) for no operation.

- Change Operation to `nop`.

Would require changing many control bits.

Squashing shown that way here for brevity.

Illustrated by placing a `nop` in `IR`.

Why not replace squashed instructions with target instructions?

Because there is no straightforward and inexpensive way ...
... to get the instructions *where and when* they are needed.

(Curvysideways and expensive techniques covered in Chapter 4.)

MIPS implementation used so far.

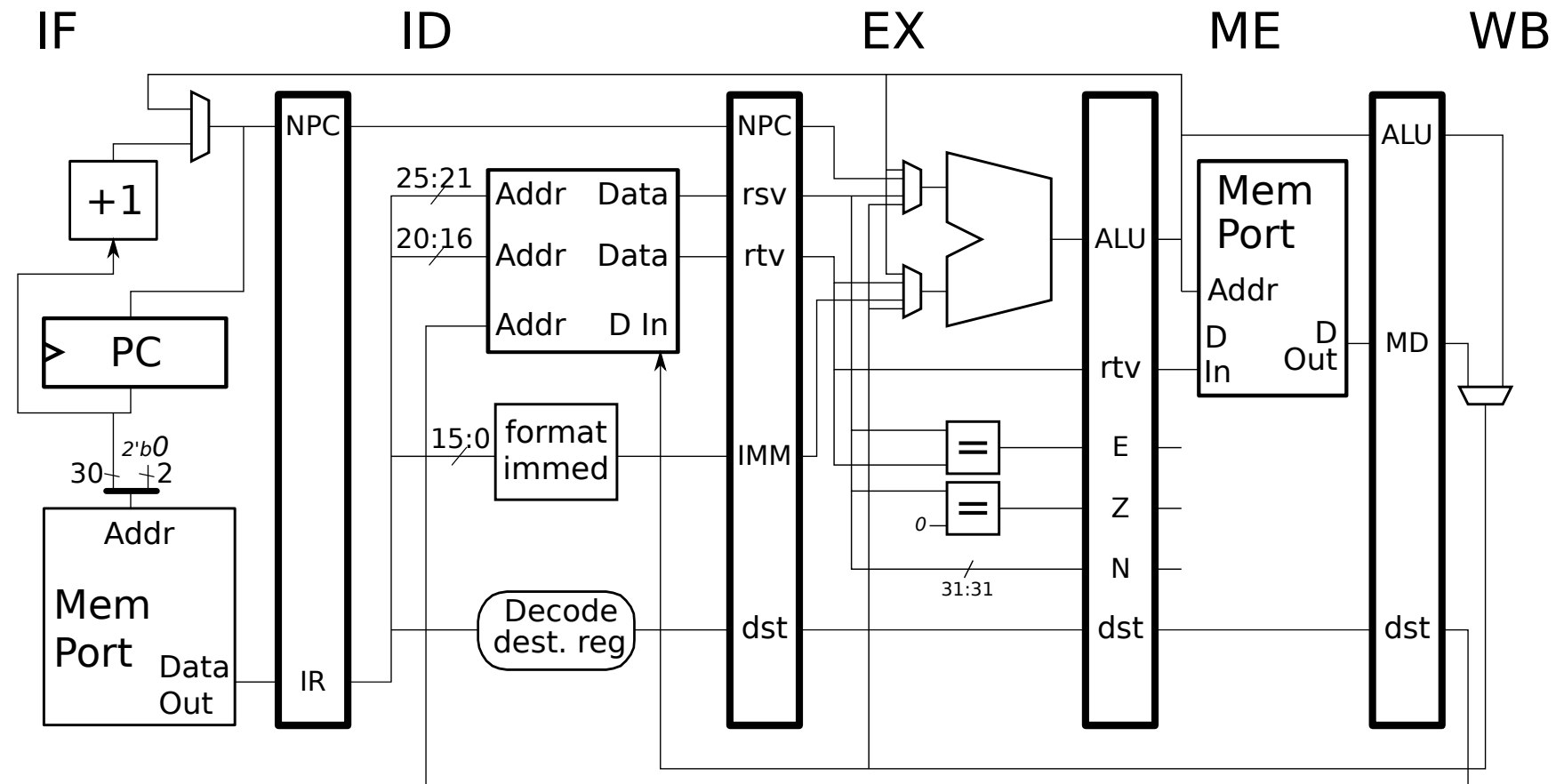

Example of correct execution

#I	Adr	Cycle	0	1	2	3	4	5	6	7	8
0x100	bgtz r4, TARGET	IF	ID	EX	ME	WB					
0x104	sub r4, r2, r5		IF	ID	EX	ME	WB				
0x108	sw 0(r2), r1			IF	IDx						
0x10c	and r6, r1, r8				IFx						
0x110	or r12, r13, r14										
...											
TARGET: # TARGET = 0x200											
0x200	xor r9, r4, r11				IF	ID	EX	ME	WB		

Branch outcome known at end of cycle 2 ...

... wait for cycle 3 when doomed instructions (`sw` and `and`) in flight ...

... and squash them so in cycle 4 they act like `nops`.

Two cycles (2, and 3), are lost.

The two cycles called a *branch penalty*.

Two cycles can be alot of cycles, is there something we can do?

Zero-Cycle Branch Delay Implementation

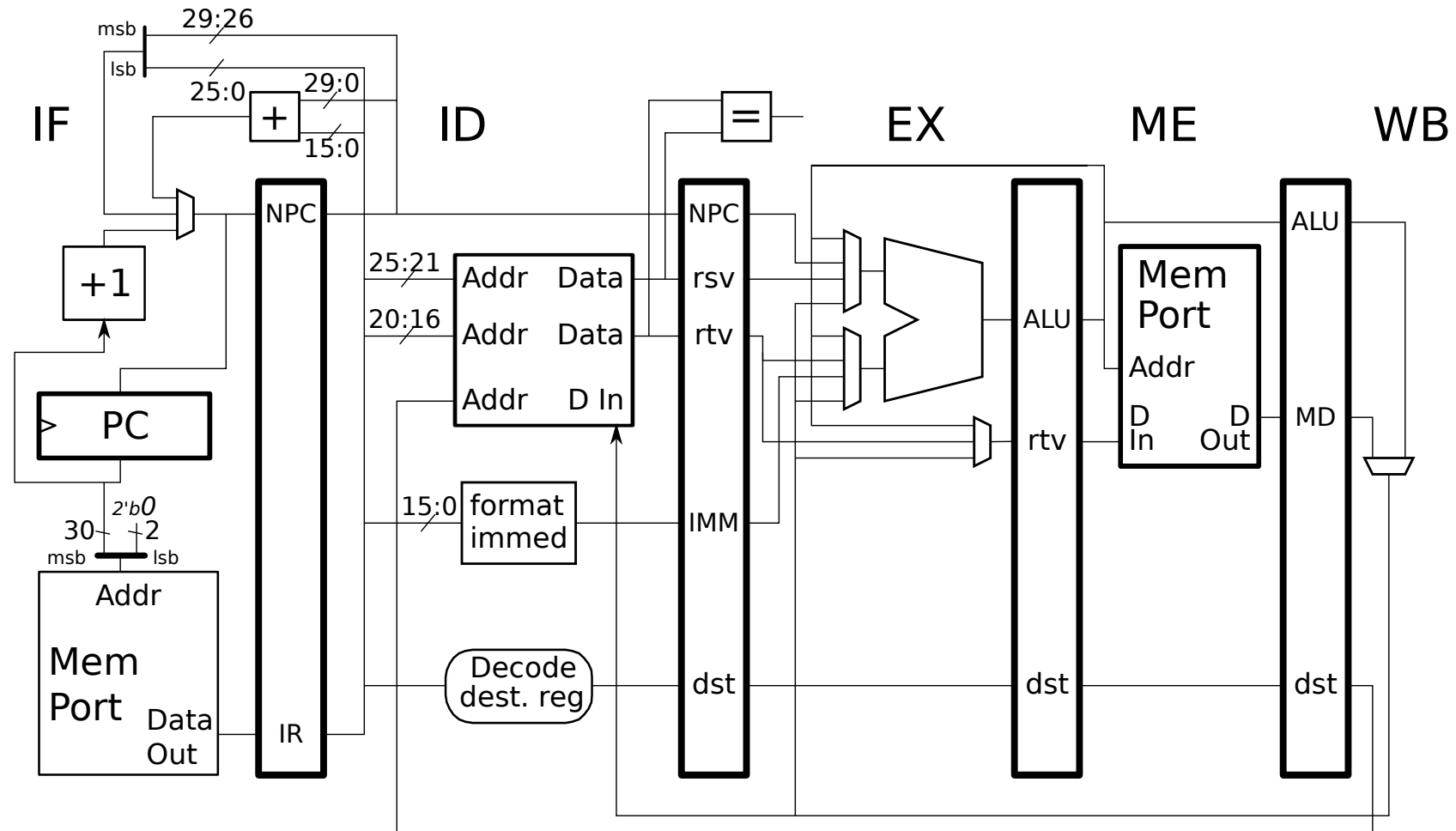

Compute branch target address in ID stage.

Compute branch target and condition in ID stage.

Workable because register values not needed to compute branch address and ...
 ... branch condition can be computed quickly.

Now how fast will code run?

#I	Adr		Cycle	0	1	2	3	4	5	6	7	8
0x100	bgtz	r4, TARGET	IF	ID	EX	ME	WB					
0x104	sub	r4, r2, r5		IF	ID	EX	ME	WB				
0x108	sw	0(r2), r1										
0x10c	and	r6, r1, r8										
0x110	or	r12, r13, r14										
...												
TARGET: #	TARGET =	0x200										
0x200	xor	r9, r4, r11		IF	ID	EX	ME	WB				

No penalty, not a cycle wasted!!

Bypassed MIPS

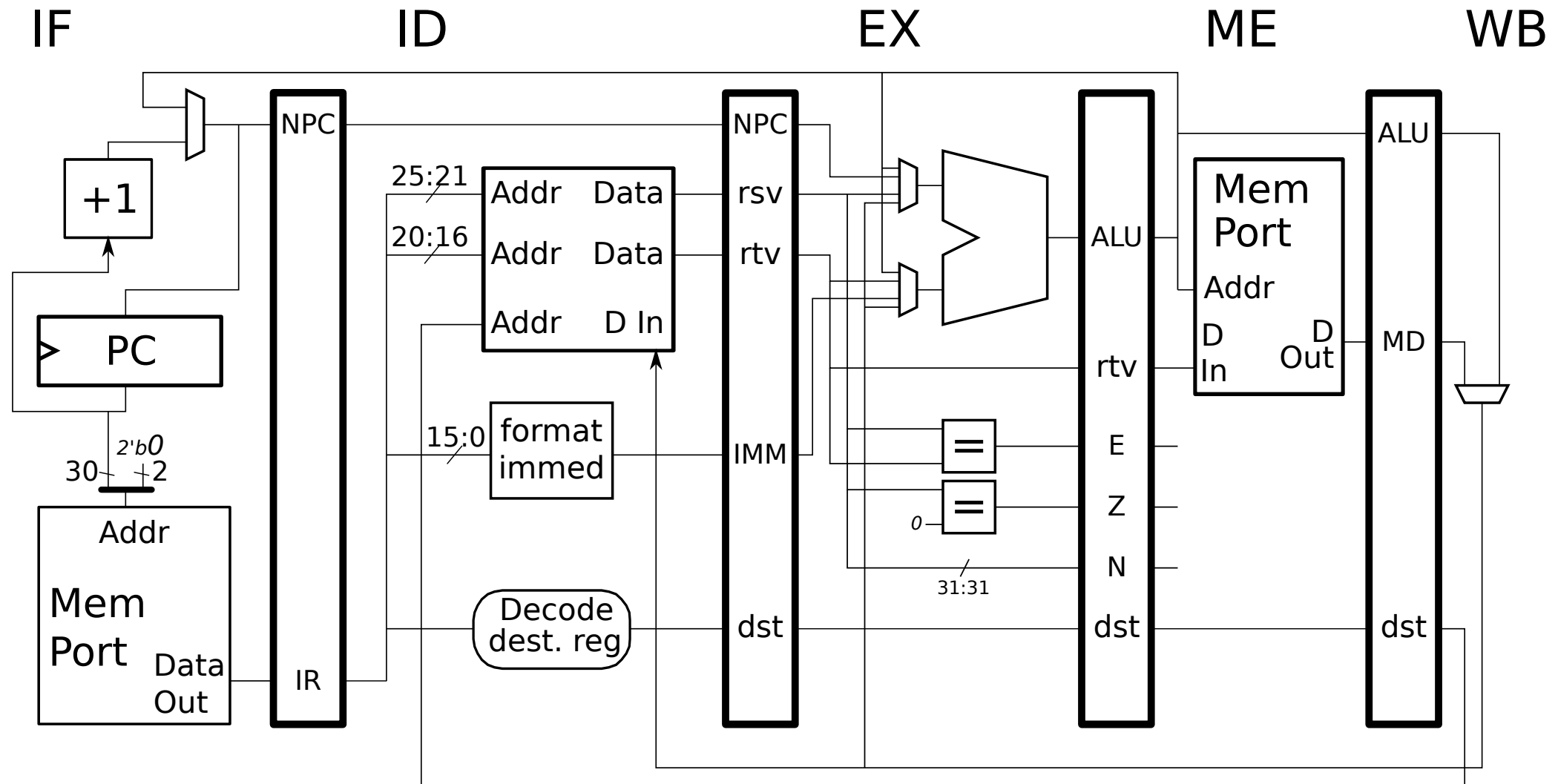

ID Branch MIPS

