

See also cache study guide.

Contents

Supplement to material in section 5.2.

Includes notation presented in class.

In essence a memory system is quite simple:

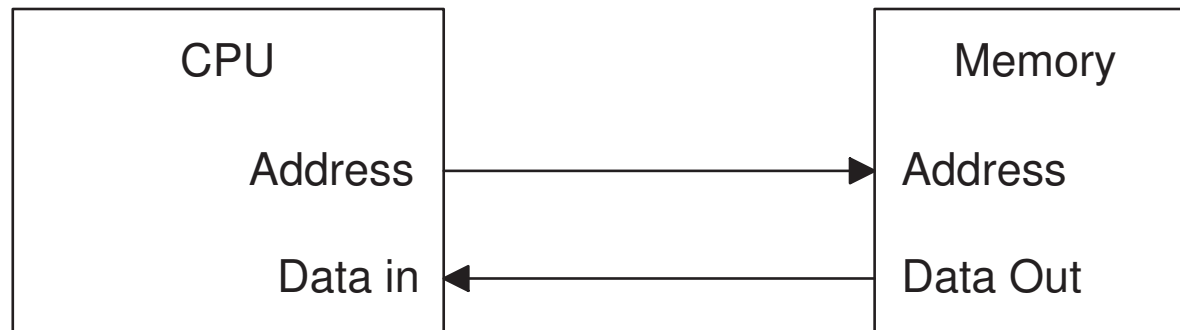

Retrieve or store data at specified effective address.

But in practice its complexity can rival that of the processor.

Address Space:

The set of addresses defined in the ISA.

Address Space Size:

The (maximum) number of bits needed to represent an address.

Symbol used in class: a .

The size of the address space defined by the MIPS32 ISA is 32 bits and so a memory address is 32 bits and there are 2^{32} memory locations.

Typical address space sizes:

DLX, MIPS32, Sun SPARC V8, IA-32, ARM T16, ARM A32, and other older ISAs, $a = 32$,

Intel 64, Itanium, MIPS64, DEC Alpha, Sun SPARC V9, ARM A64, $a = 64$.

Real Address Space: a.k.a. Physical Address Space

The set of addresses used by main memory.

Real Address:

An address in a real address space.

Given a real address, can open up computer's case and point to data.

Virtual Address Space:

The set of addresses usually used by programs.

Physical location used for a virtual address can change as a program runs.

Given a virtual address, cannot point to a chip and say data is there...

... since location of data is not pre-determined and location can change.

Usage of Virtual Address

Virtual Address “Users”

Instructions in most programs ...
... including our code samples from class.

Usually the L1 cache, sometimes the L2 cache (covered later).

Real Address “Users”

The first instructions that a computer runs after it resets.

Low-level OS code written by those getting A+'s in this class.

Memory devices use physical addresses.

Translation between Virtual and Real Addresses

Hardware between CPU and memory translates from virtual to physical address.

Depending on design, cache uses virtual or physical addresses.

Processor can switch between virtual and real addresses.

Only real addresses used in this set of notes.

Character:

What a memory address refers to; defined by the ISA.

Number of bits in a character denoted c

In most systems, $c = 8$ bits and called a byte.

In MIPS `lb r1, 0(r2) ...`

... loads the one character at address `0(r2)` into register `r1`.

Bus Width:

The number of bits brought into the processor in a single memory access.

Symbol used in class w .

The number of bits accessed by an instruction may be less, the other bits are ignored.

This is an implementation feature.

In any reasonable system w is a multiple of c .

Typical values, $w = 64$ bits.

```
! Data in memory:
! 0x1000: 5, 0x1001: 6, 0x1002: 7, 0x1003: 8.
! 0x1004 to 0x1007: 0x11111111
addi r1, r0, 0x1000
lb r10, 0(r1) ! Eff. addr = 0x1000, r10 <- 0x00000005
lb r11, 1(r1) ! Eff. addr = 0x1001, r11 <- 0x00000006
lb r12, 2(r1) ! Eff. addr = 0x1002, r12 <- 0x00000007
lb r13, 3(r1) ! Eff. addr = 0x1003, r13 <- 0x00000008
lh r15, 0(r1) ! Eff. addr = 0x1000, r15 <- 0x00000506
lh r16, 2(r1) ! Eff. addr = 0x1002, r16 <- 0x00000708
lw r20, 0(r1) ! Eff. addr = 0x1000, r20 <- 0x05060708
```

Relationship Between Address and Data on Bus

If $w = c$ then data on bus is for a single address.

If $w/c = 2$ then data on bus is for two consecutive addresses.

If $w/c = D$ then data on bus is for D consecutive addresses.

When load instructions refer to less than w/c addresses ...

... the processor hardware extracts bits needed ...

... using an *alignment network*.

Alignment Network:

The hardware that shifts and pads or sign-extends data on the bus so that it can be used by the processor.

Bus width fixed at w bits ...

... but instructions may expect fewer bits.

Alignment network extracts bits that instruction needs ...

... and pads unused high-order bits with zeros or sign.

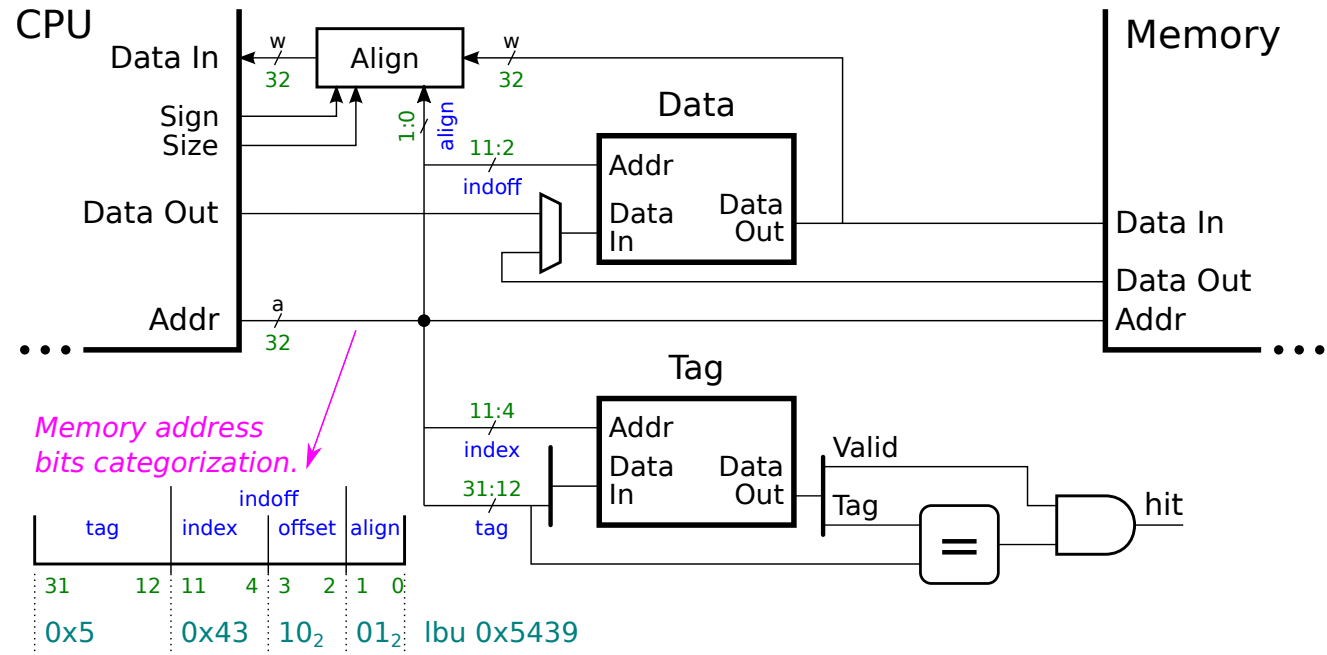

```
! r1 = 0x1003
! MEM[0x1000..0x100F] = 0x80 0x81 0x82 ... 0x8f
lb r2, 0(r1)    ! Bus contents: 0x80 0x81...0x8f, r2<-0xffffffff83
lu r3, 0(r1)    ! Bus contents: 0x80 0x81...0x8f, r3<-0x83
lw r4, 1(r1)    ! Bus contents: 0x80 0x81...0x8f, r4<-0x84858687
```

For **lb** alignment network extracts bits 24 : 31 from bus ...
 ... padding high-order bits with 1 (MSB of 0x83).

For **lu** alignment network extracts bits 24 : 31 from bus ...
 ... padding high-order bits with 0 (unsigned load).

For **lw** alignment network extracts bits 32 : 63 from bus ...
 ... no padding since register and data are both 32 bits.

Cache Motivation

Loads and stores are performed frequently.

Fast memory devices are expensive and size limited and ...

... cheap memory devices are slow.

By organizing these devices into a *cache* performance will be ...

... almost as fast as expensive devices ...

... almost as cheap as slow devices.

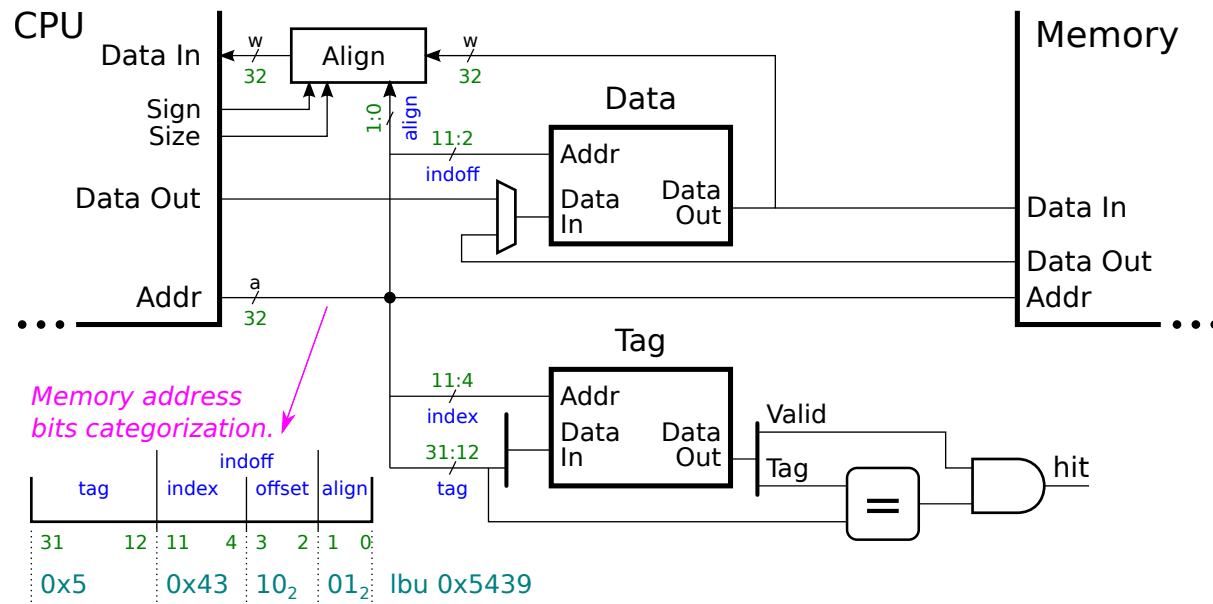

Cache Idea

Use cheap devices to implement (real part of) address space.

Use expensive devices to duplicate parts of address space.

Definition above can apply to many types of caches, *e.g.* disk caches.

This set concerned with main-memory caches.

Cache Use

If accessed data in expensive devices, data returned quickly.

Called a *hit*.

If accessed data not in expensive devices ...

... data copied from cheap to expensive devices ...

... and passed to processor (taking much more time than a hit).

Called a *miss*.

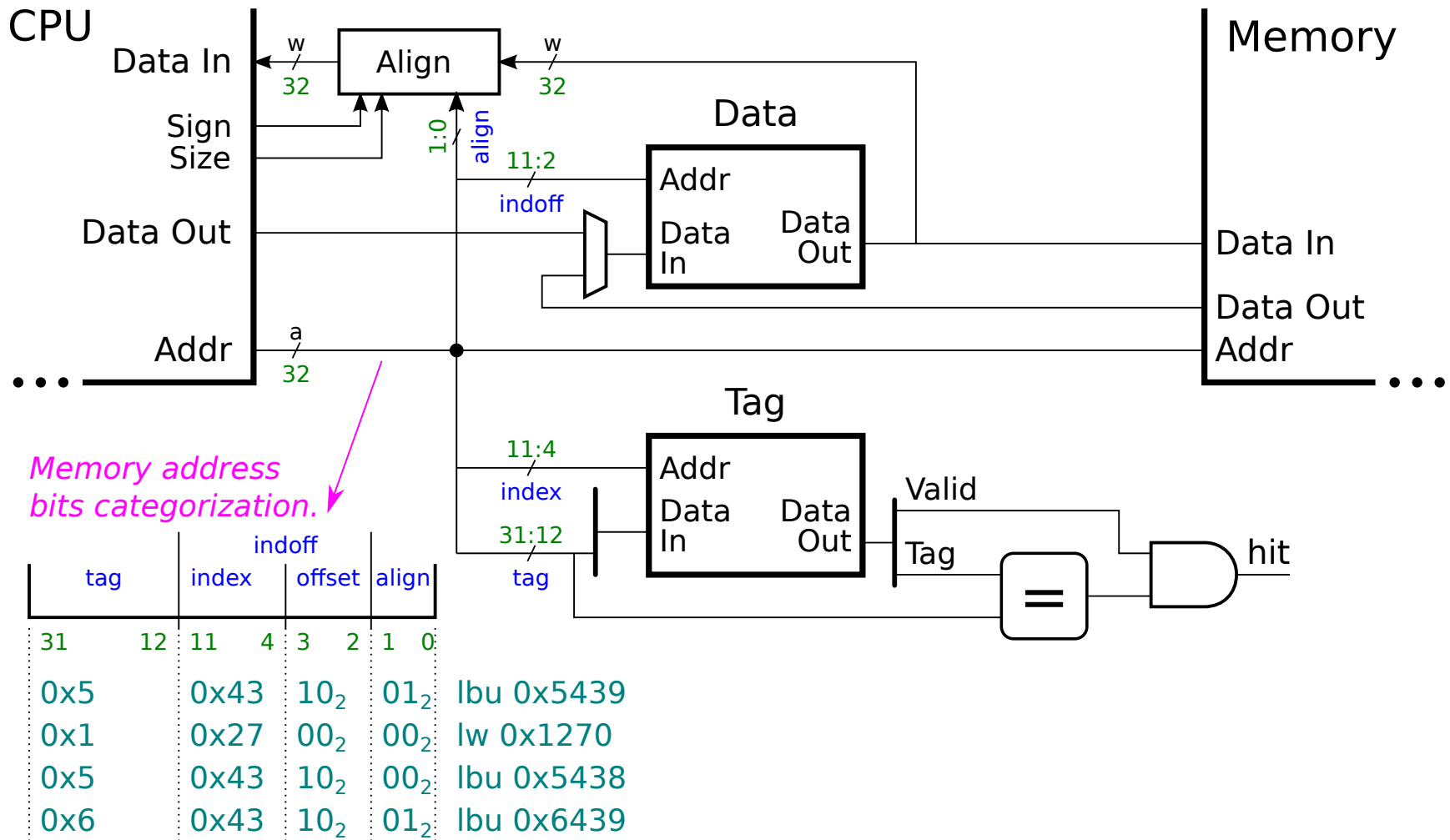

Definitions

Cache:

High speed storage that holds data which is normally kept in larger, slower storage. The larger storage is ordinarily accessed only after not finding data in the cache.

Hit:

Data corresponding to the effective address found in the cache.

Miss:

Data corresponding to the effective address not found in the cache and had to be read from memory (or a higher cache level).

Organization of Simple Cache

Uses two memories, called *data store* and *tag store*. (Both expensive.)

Data Store:

The cache memory used to hold cached data.

Data memory holds copies of data held by cheap devices.

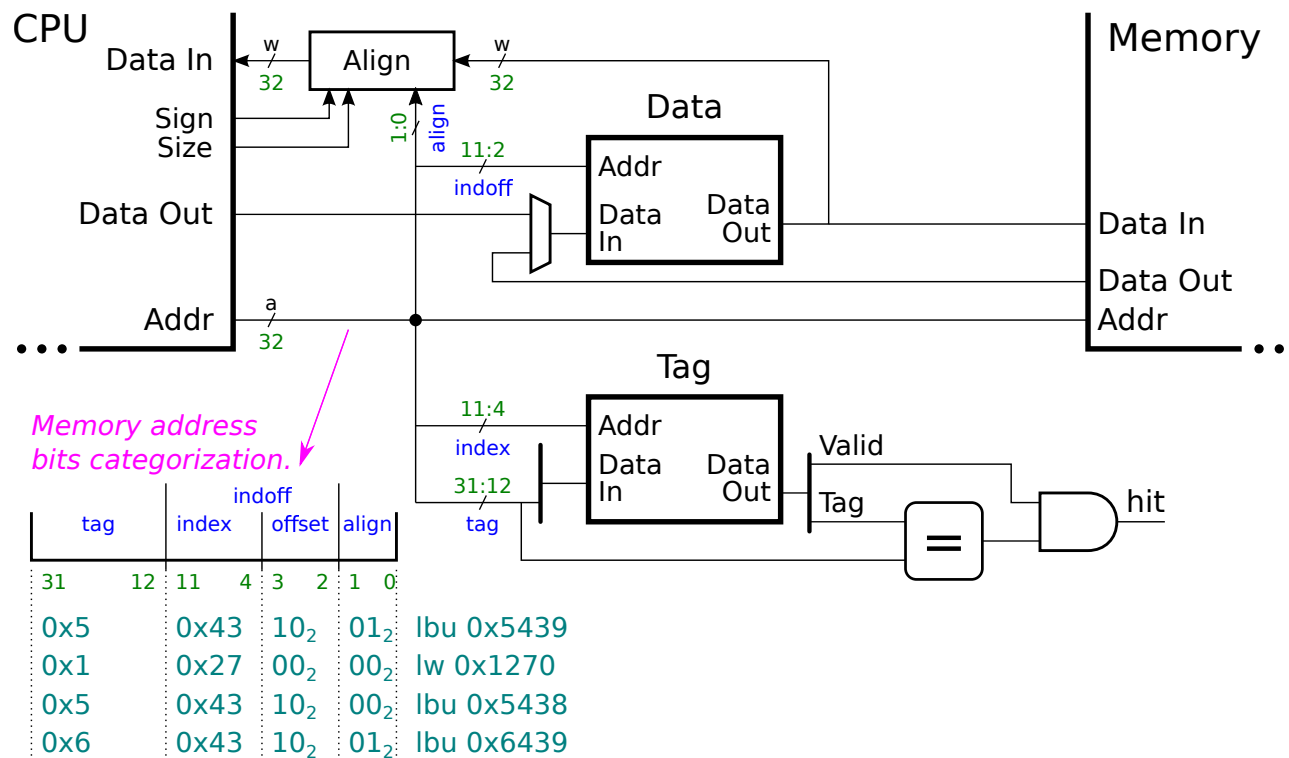

Organization of Simple Cache

Tag Store:

Cache memory that holds information about cached data, including part of the cached data's addresses, called a *tag*, and status bits.

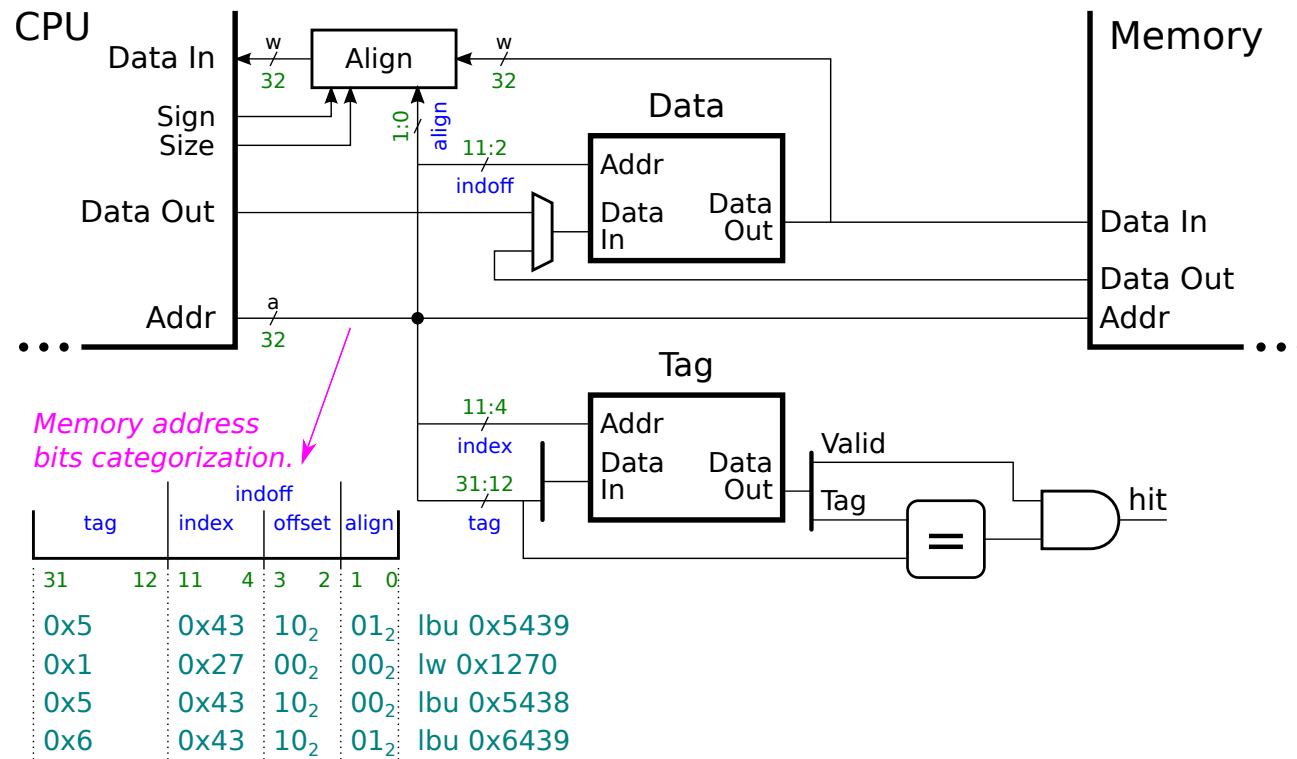

Organization of Simple Cache

Line: also called a block

The unit of storage in a cache.

Consists of one or more bus-width's worth of data.

On a miss an entire line's worth of data copied from main memory.

The size of a line usually given in terms of characters.

Symbols used in class: L line size in characters, $l = \log_2 L$.

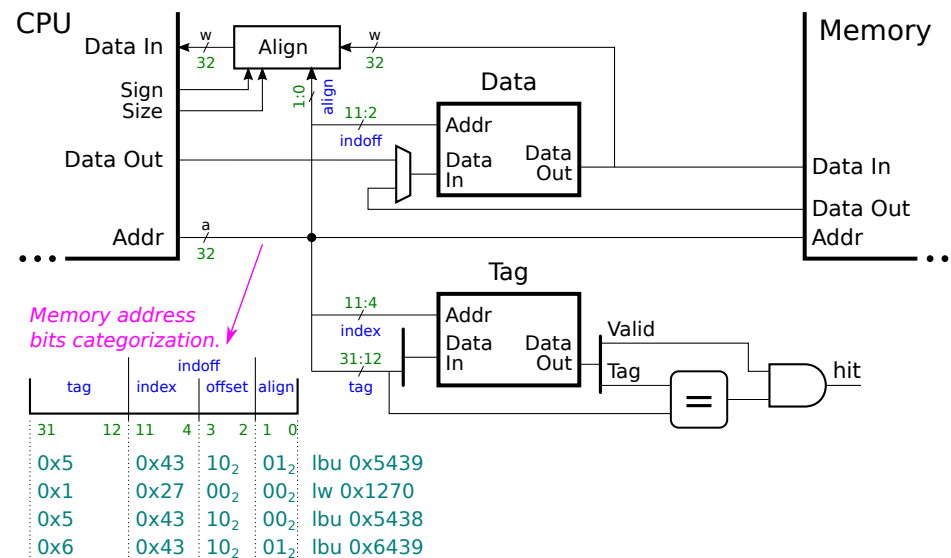

Organization of Simple Cache

Set:

Lines that share a common *index*.

Index explained further below.

One measure of a cache is the number of sets it can hold.

The cache capacity is the product of number of sets, lines per set, and line size.

Symbol: s , denotes \log_2 of the number of sets.

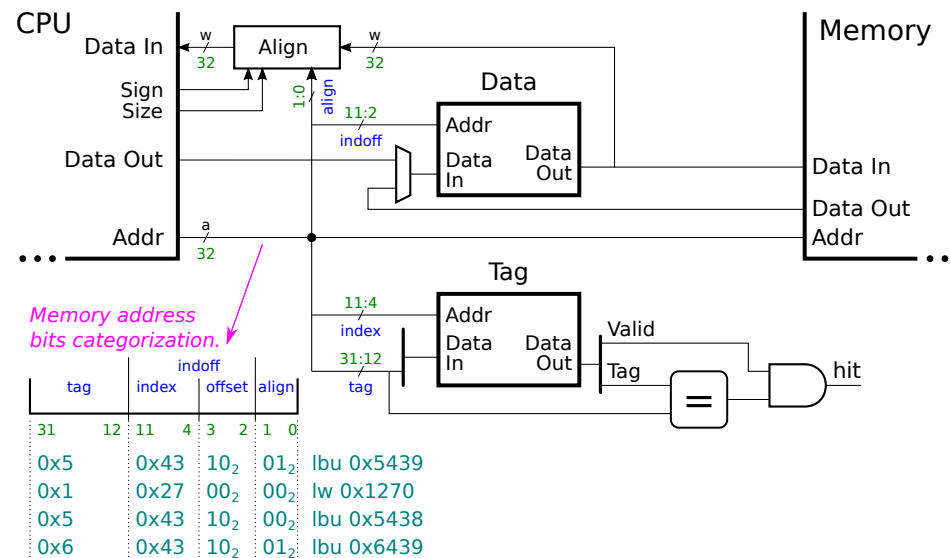

Address bit positions, *fields*, can be used to locate data in cache.

For

a -bit address space,

2^s -set cache,

2^l -character lines,

and $d = \log_2(w/c)$ character bus width

the fields would be as follows:

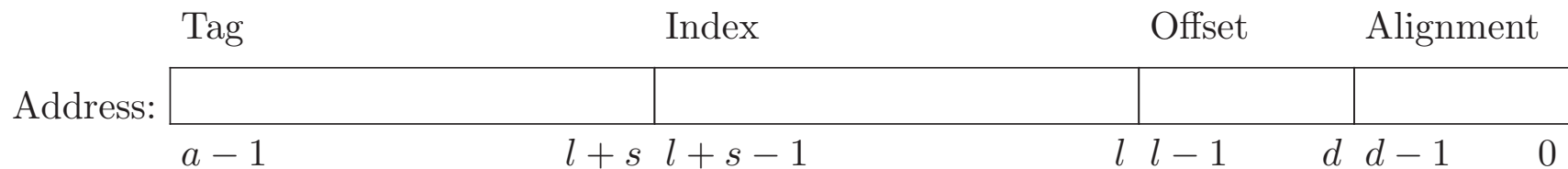

More Cache Structure and Address Bits

Details on later slides.

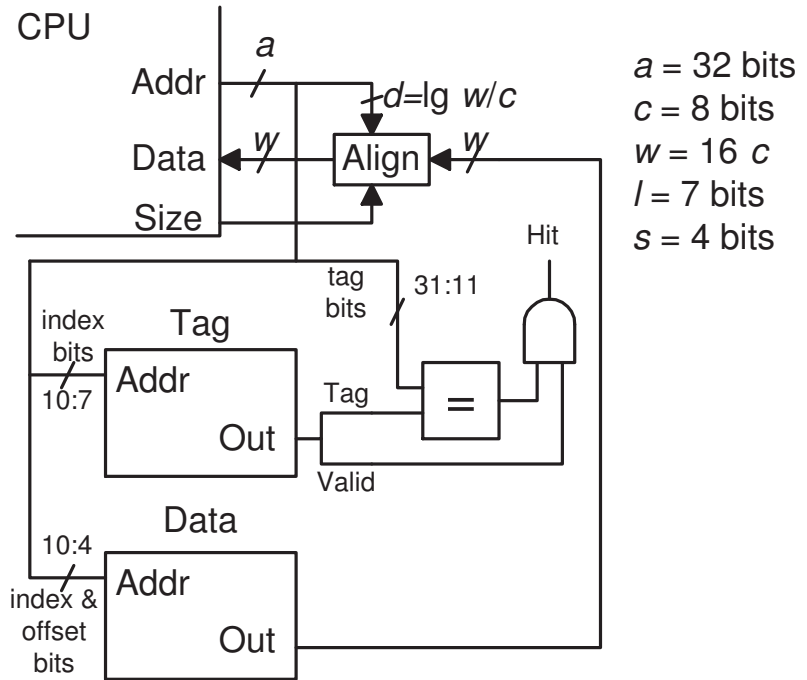

$a = 32$ bits
 $c = 8$ bits
 $w = 16$ c
 $l = 7$ bits
 $s = 4$ bits

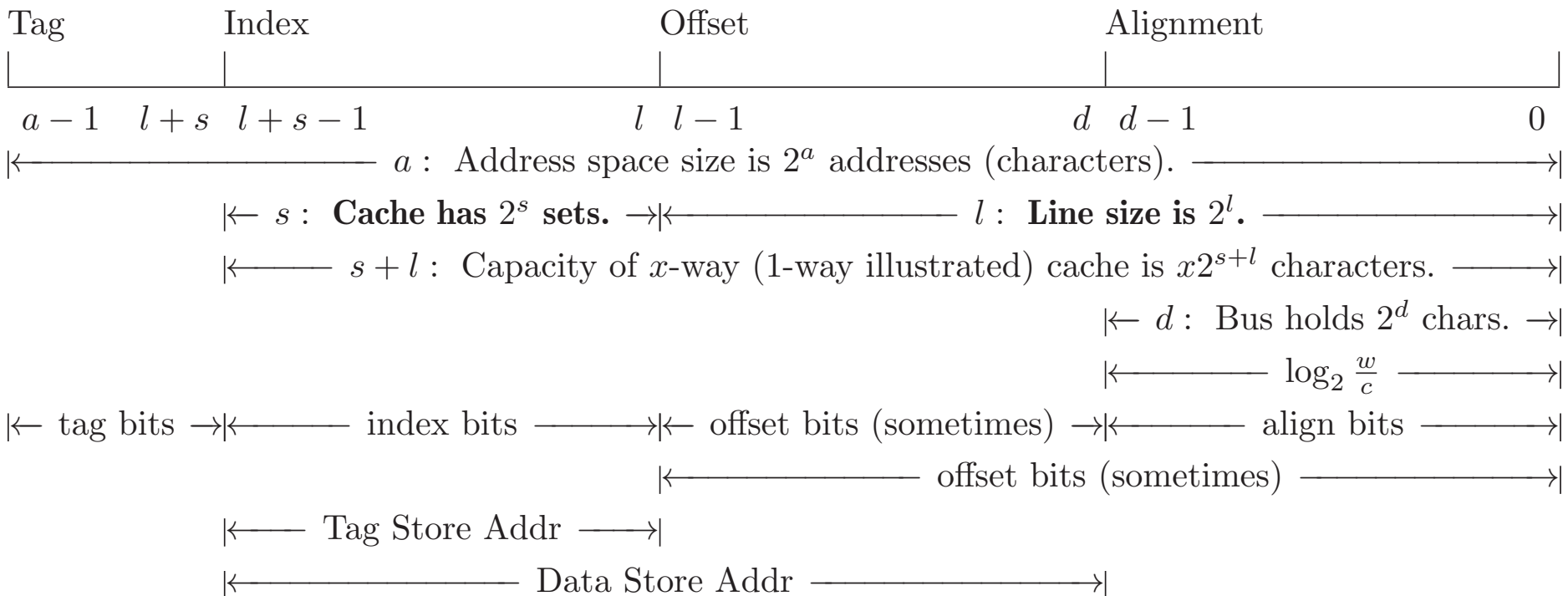

Alignment Bits:

The low-order address bits that refer to a character position on the bus.

Bits: $0 : (d - 1)$

where $d = \log_2(w/c)$ (characters per bus width).

Assuming aligned fetches, the d least significant bits of an address will either be zero or ignored.

This part of the address is ignored by the cache.

These bits are labeled “offset” in figure 5.8. Three of those five offset bits are also alignment bits.

Example: Let $w = 32$ and $c = 8$.

Then the bus can hold 4 characters and so $d = \log_2 \frac{32}{8} = 2$.

If the 2 least significant address bits are 0 then the address refers to the first character position, bits 0:7 (assuming little-endian numbering).

If the 2 least significant address bits are 01 then the address refers to the second character position, bits 8:15, etc.

Offset:

The low-order address bits that refer to a character position within a line.

Bits: $d : (l - 1)$,

(A line can hold more than one bus-width worth of data.)

This and the index are used to look up the data in each of the data memories.

These bits are labeled “offset” in figure 5.8. Two of those five bits are offset bits as defined here and are shown connected (along with index) to the address inputs of the data memories.

Index:

The address bits, adjacent to the offset, that specify the cache set to be accessed.

Bits: $l : (l + s - 1)$

Used to look up a tag in each of the tag memories.

Along with the offset, used to look up the data in each of the data memories.

These are labeled “index” in figure 5.8 and are shown connecting to the data and tag memories.

Tag:

The address bits that are neither index nor offset bits.

Bits: $(l + s) : (a - 1)$

An address bit is either an offset bit, an index bit or a tag bit.

Tag bits are stored in tag memories.

They are later are retrieved and compared to the tag of the address being accessed.

There is a hit if a tag matches and the corresponding valid bit is 1.

Labeled “tag” in figure 5.8. The figure omits the data-in port to the tag memories, which is used for writing a new tag and valid bit on cache replacement.

Tag Store

Memory with one entry for each line.

Each entry holds ...

... tag (high-order part of line address) ...

... valid bit (indicating that line is in use) ...

... dirty bit (in write-back caches, indicating higher levels not updated).

Write Options

Write Through:

A cache feature in which memory (or a higher-level cache) is updated on every store, even if the write address is cached.

Write Back:

A cache feature in which memory is not accessed on a write hit. Data is written into the cache and is only written into memory when the line is replaced.

A cache is either write through or write back.

Write Allocate:

A cache feature in which data is written into a cache (perhaps replacing a line) after a write miss. (See write around.)

Write Around: or No-write allocate

A cache feature in which on a cache miss data is written to memory and not into the cache.

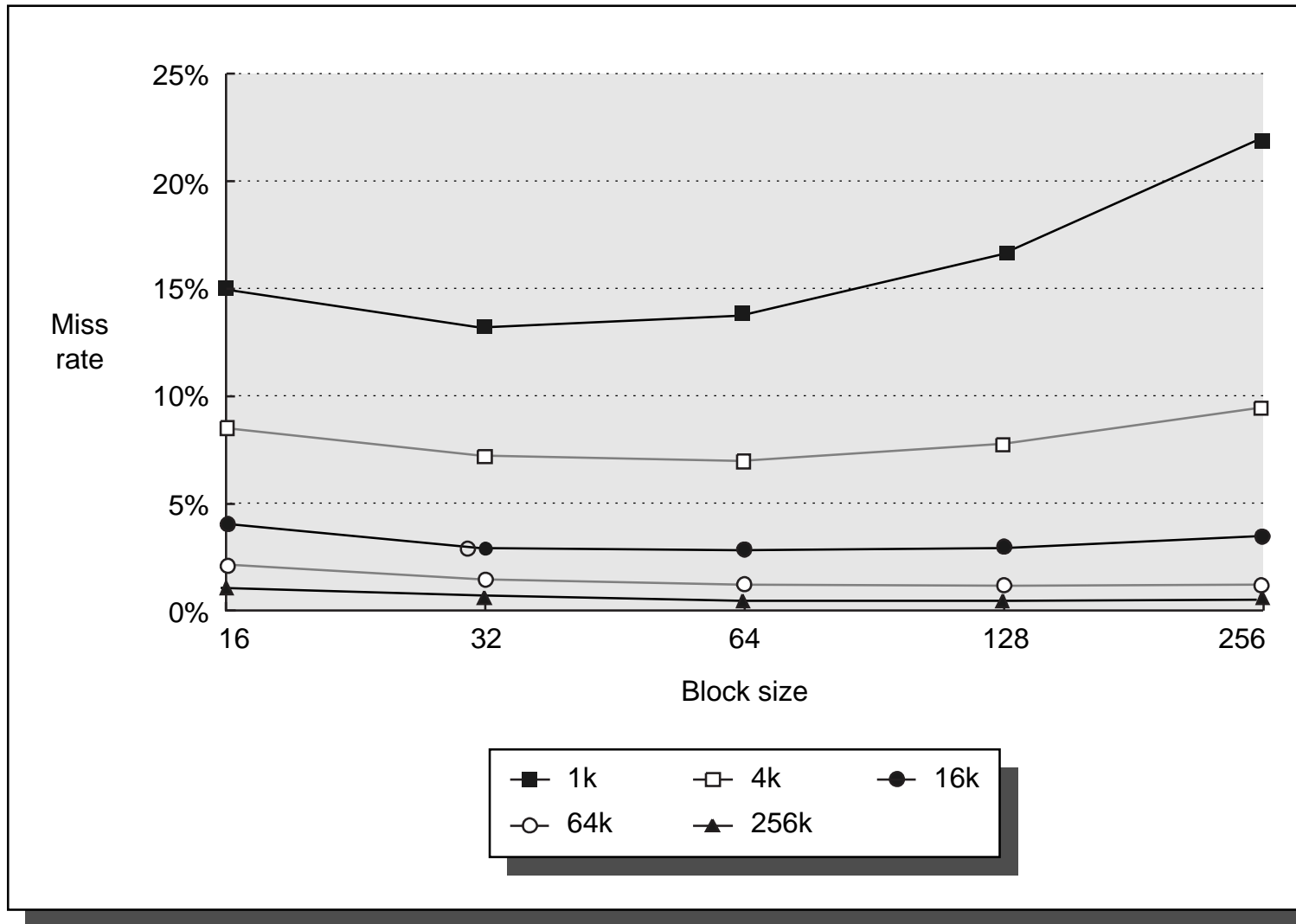

FIGURE 5.11 Miss rate versus block size for five different-sized caches.

Motivation

A direct-mapped cache can store no more than one line with a particular index.

Poor performance when program frequently accesses two lines with same index.

Example, 4 kiB cache, line size $L = 2^l = 2^8$, number of sets $2^s = 2^4 = 16$.

```
extern char *a; // Big array, allocated elsewhere.
for ( int i=0; i<1024; i++ ) {
    int b = a[ i ];           // At most one hit.
    int c = a[ i + 0x1000 ]; // Always misses.
    d += b + c;
}
```

Note, hit rate much better if cache size doubled ...

... or using a *set-associative* cache of same or smaller size.

Idea

Duplicate a direct-mapped cache x times ...
... each duplicate sometimes called a *way*.

In typical set-associative caches associativity from 2 to 8.

Simultaneously look up line in each duplicate.

Can hold x lines with same index.

Set:

Storage for lines with a particular index.

Associativity:

Number of lines that a set can hold.

x -Way Set-Associative Cache:

A cache with associativity x .

Replacement Strategy:

Method used to choose line to replace (when space needed).

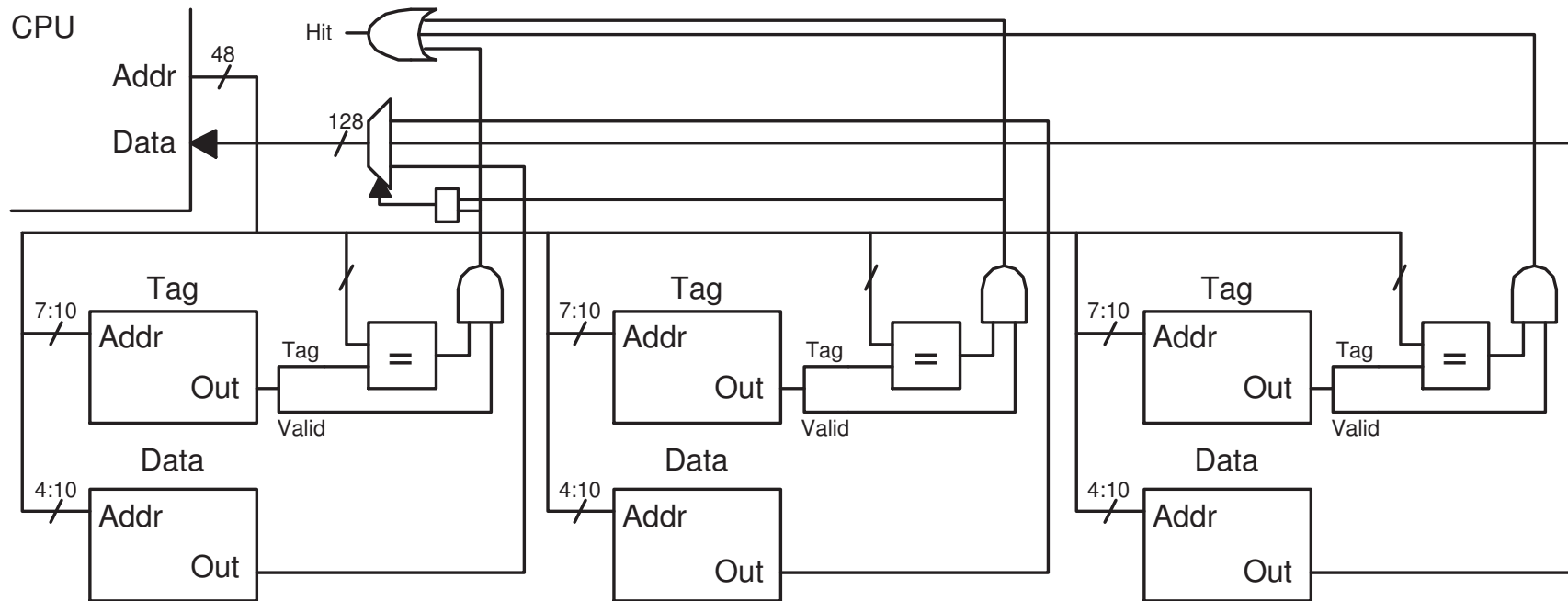

Memory System: $a = 48$, $c = 8$ bits, and $w = 128$ bits.

Cache: Three-way associativity (set holds 3 lines), 128-byte lines (each line holds 8 bus-widths of data), 16 sets.

Capacity: $3 \times 16 \text{ B} \times 2^{10-4+1} = 6144 \text{ B}$.

Problem not faced in direct-mapped caches: which line to evict.

LRU:

A replacement strategy in which the least-recently used (accessed) line is considered.

Is effective because address references usually exhibit temporal locality.

Easy to implement if associativity small.

Too time consuming if associativity is large.

If associativity is large (> 16) LRU can be approximated.

Random

Usually approximated ...

... for example, using least significant bits of a cycle counter.

Less effective than LRU ...

... but effective enough and easy to implement.

Miss Categories

Compulsory: or *Cold* Miss

A miss to a line that was never cached.

Conflict Miss:

A miss on a system that would not occur on one using a fully-associative cache of the same size.

Capacity Miss:

A miss on a system that would also occur on one using a fully-associative cache of the same size.

Direct Mapped Cache:

A 1-way set-associative cache (not really set associative).

Fully Associative Cache:

A set-associative cache with one set ($s = 0$).

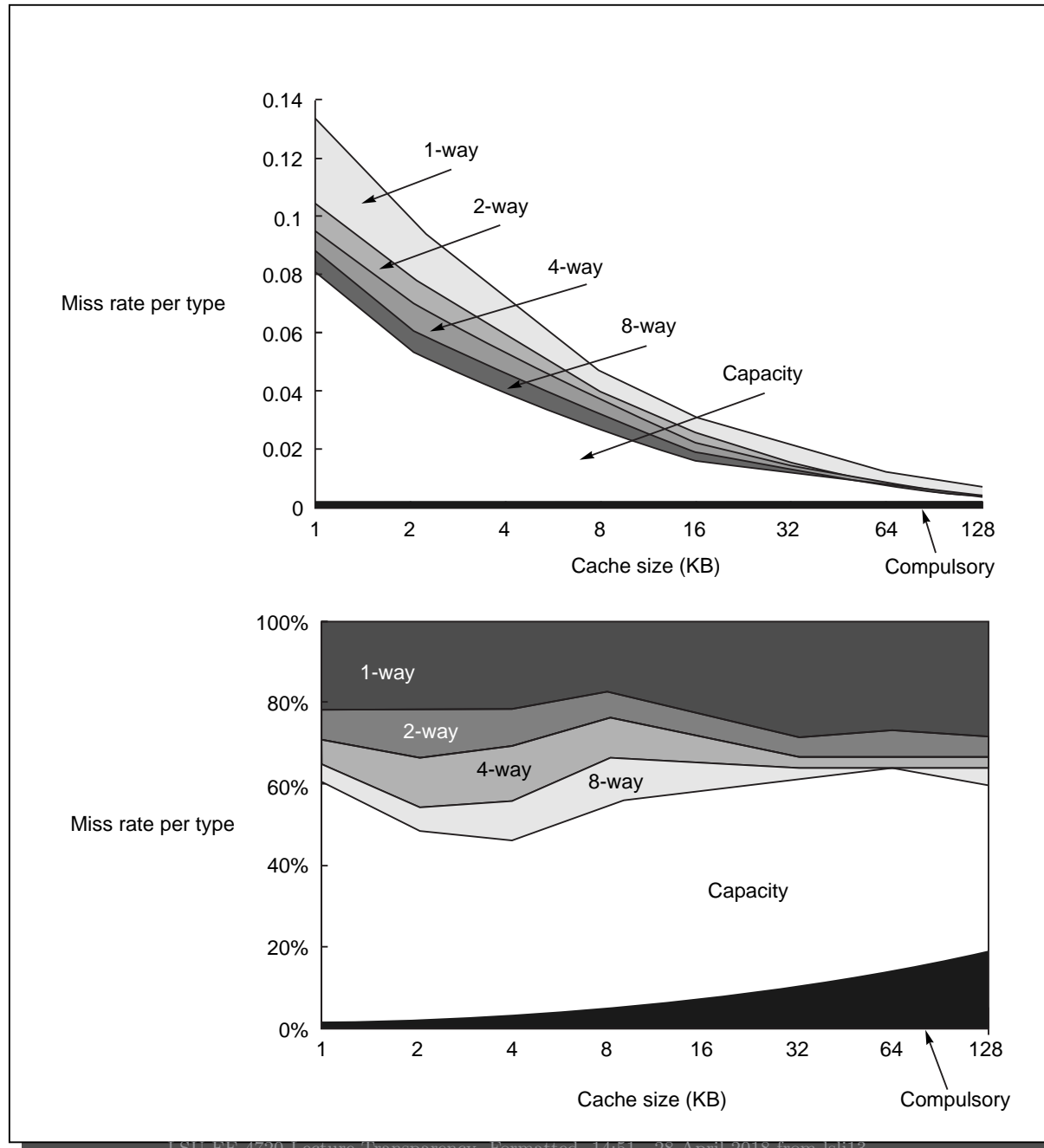

FIGURE 5.10 Total miss rate (top) and distribution of miss rate (bottom) for each

What Program Does

First, program exactly fills up cache using minimum number of accesses.

Then, program generates hundreds of misses accessing only five items.

```
#include <stdio.h>

#define LG_LINE_SIZE 4
#define LG_SET_COUNT 10
#define ASSOCIATIVITY 4

#define SET_COUNT (1<<LG_SET_COUNT)
#define CACHE_SIZE ( ASSOCIATIVITY << ( LG_LINE_SIZE + LG_SET_COUNT ) )

char a[ 2 * CACHE_SIZE ];

int main(int argv, char **argc)
{
    int dummy = 0;
```

Fill up cache with minimum number of accesses.

```
{
  char *addr = &a[0];
  int linesize = 1 << LG_LINE_SIZE;

  for ( int w=0; w<ASSOCIATIVITY; w++ )

    for ( int s=0; s<SET_COUNT; s++ )
      {
        dummy += *addr;
        /* Below, increment index part of address. */
        addr += linesize;
      }
}
```

Generate lots of misses while accessing only five ($\text{ASSOCIATIVITY} + 1$) array elements.

```
{
  int deadly_stride = 1 << ( LG_LINE_SIZE + LG_SET_COUNT );

  for ( int i=0; i<100; i++ )
    {
      char *addr = &a[0];

      for ( int w=0; w<=ASSOCIATIVITY; w++ )
        {
          dummy += *addr;
          /* Below: Increment tag part of address. */
          addr += deadly_stride;
        }
    }
}
```

Problem with systems using only one cache:

Need multiple ports, one for IF and one or more for load/stores ...
... adding ports increases latency.

Larger caches have higher latencies ...
... must balance miss ratio with hit latency.

Solutions

Split cache into separate *instruction* and *data* caches (all at same level).

Split cache into multiple *levels*, abbreviated *L1*, *L2*, etc.

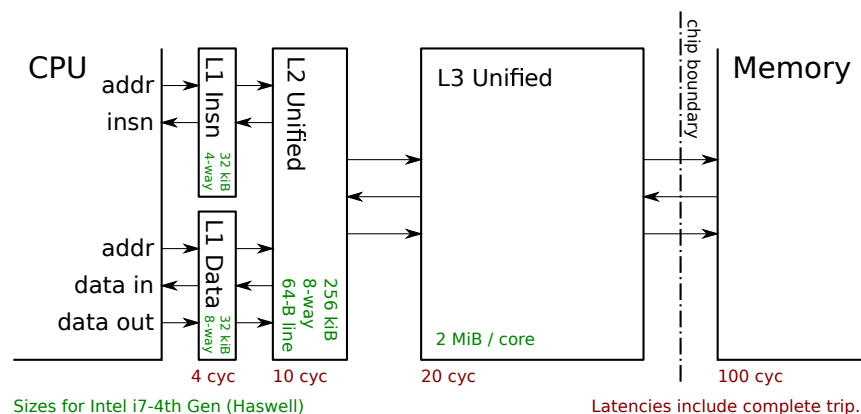

Idea:

Split caches into independent parts.

Each part used by a different part of CPU.

Common Split: Instruction/Data

Instruction Cache:

A cache only used for instruction fetches.

Data Cache:

A cache only used for data reads and writes.

Unified Cache:

A cache that can be used for instructions and data.

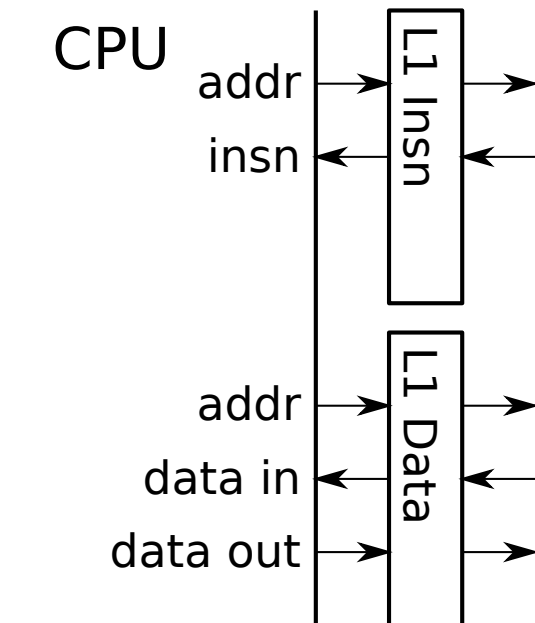

Multiple-Level Caches

Due to fabrication technology limitations and addressing logic needed...
... **cache latency increases** as **cache size increases**.

Latency and hit ratio balanced using multiple cache levels.

Cache level indicates “distance” from CPU.

Lowest-level (level one) cache checked first ...
... if data not present second level checked ...
... until data found or there are no more levels.

Choice of Size for Cache Levels

Level 1 Criteria

Designed to meet a target hit latency. *E.g.*, one cycle.

To achieve speed may be direct mapped or of low associativity.

On same chip as CPU.

Level 2 Criteria

Hit latency can be much longer, *e.g.*, 10 cycles.

Latency can be met with a much larger size and associativity.

Often on same chip as CPU.

Size either chosen ...

... to fill the rest of the chip (when L3, if any, is off chip) ...

... or to meet a latency goal (when L3 is on chip).

Level 3 Criteria

If on chip, fill chip area.

Global Hit Ratio:

Number of hits to any level divided by number of accesses to cache.

Local Hit Ratio of a Level:

Number of hits to a level divided by number of access that reach that level.

Cache Organization in Intel i7 4th Gen (Haswell).

Note: (Same as Nehalem, Sandy Bridge).

Chip has from 2 to 10 cores, sizes below are per core.

Level-One Caches

Separate instruction and data caches.

Each is 32 kiB, data cache is 8-way, insn cache is 4-way.

Level-Two Cache

Size is 256 kiB, 8-way.

Level-Three Cache

Size varies with model, about 2 MiB per core.

L3 cache is shared by all cores.

Cache Organization in Intel i7 4th Gen (Haswell).

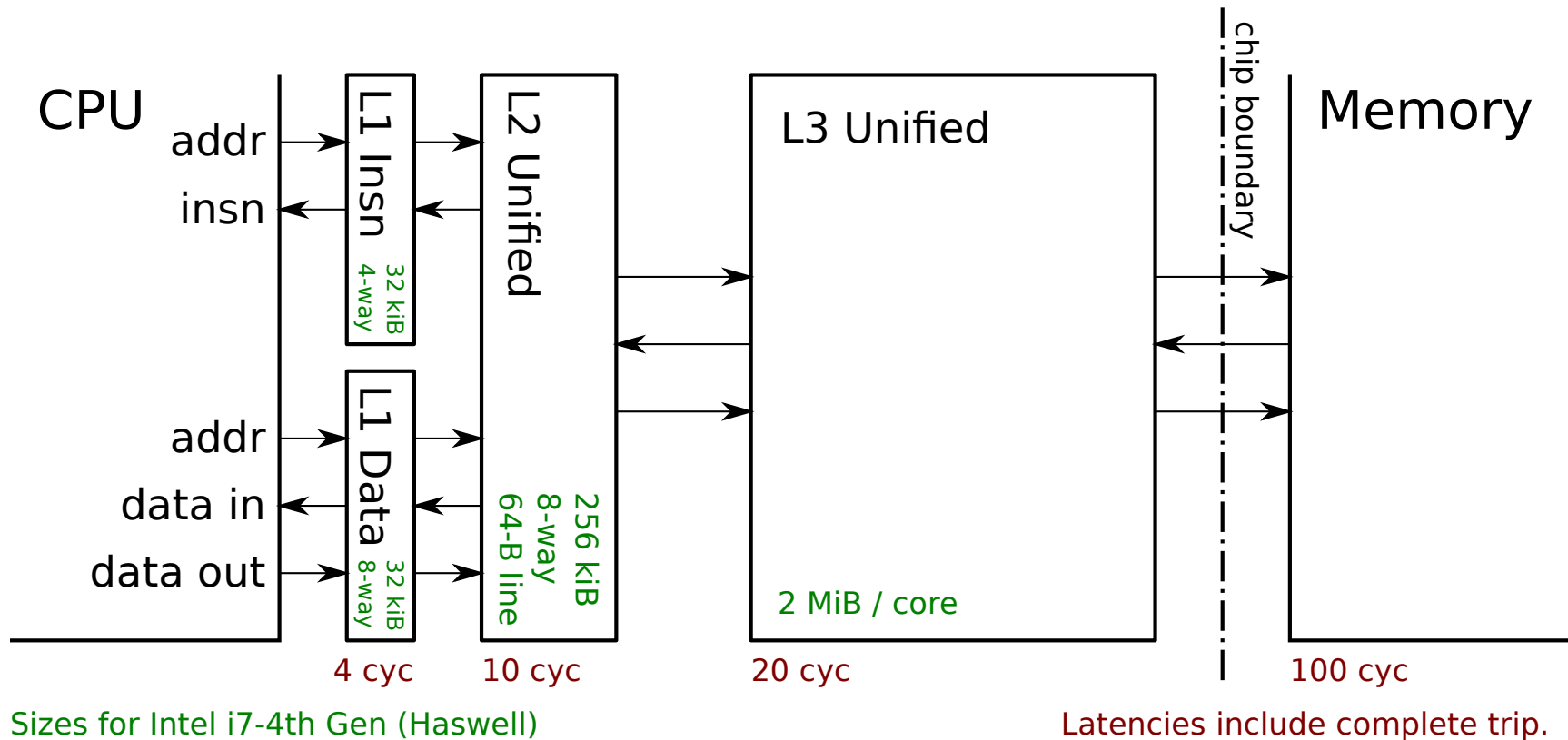

Note: Connections to L3 simplified, in particular connection between cores and to memory controller are omitted.

Lock-Free: or Non-Blocking Cache

A cache that can continue to handle accesses while processing a miss.

Multilevel Inclusion:

Describes a multiple level cache in which any data found in a lower level (closer to CPU) will also be found in the higher level.