



*Pipeline Segments* a.k.a. *Pipeline Stages*

Divide pipeline into *segments*.

Each segment occupied by at most one instruction.

At any time, different segments can be occupied by different instructions.

Segments given names: **IF**, **ID**, **EX**, **MEM**, **WB**

Sometimes **MEM** shortened to **ME**.

*Pipeline Registers* a.k.a. *Pipeline Latches*

Registers separating pipeline segments.

Written at end of each cycle.

To emphasize role, drawn as part of dividing bars.

Registers named using pair of segment names and register name.

For example, **IF/ID**.IR, **ID/EX**.IR, **ID/EX**.A (used in text, notes).

`if_id_ir`, `id_ex_ir`, `id_ex_rs_val` (used in Verilog code).

*Pipeline Execution Diagram*

Diagram showing the pipeline segments that instructions occupy as they execute.

Time on horizontal axis, instructions on vertical axis.

Diagram shows where instruction is at a particular time.

Cycle	0	1	2	3	4	5	6
add r1, r2, r3	IF	ID	EX	MEM	WB		
and r4, r5, r6		IF	ID	EX	MEM	WB	
lw r7, 8(r9)			IF	ID	EX	MEM	WB

A vertical slice (*e.g.*, at cycle 3) shows processor activity at that time.

In such a slice a **segment should appear at most once** ...

... if it appears more than once execution not correct ...

... since a segment can only execute one instruction at a time.

## Pipeline Control

Setting control inputs to devices including ...

... multiplexor inputs ...

... function for ALU ...

... operation for memory ...

... whether to clock each register ...

... *et cetera*.

Options for controlling pipeline:

- Decode in ID  
Determine settings in ID, pass settings along in pipeline latches.
- Decode in Each Stage  
Pass opcode portions of instruction along.  
Decoding performed as needed.

Real systems decode in ID.

For clarity, diagrams misleadingly imply decoding in stage needed ...  
... by passing entire instruction along.

Example given later in this set.

Remember

Operands **read from** registers in ID...  
... and results **written to** registers in WB.

Consider the following **incorrect execution**:

---

! Cycle	0	1	2	3	4	5	6	7
add r1, r2, r3	IF	ID	EX	MEM	WB			
sub r4, r1, r5		IF	ID	EX	MEM	WB		
and r6, r1, r8			IF	ID	EX	MEM	WB	
xor r9, r4, r11				IF	ID	EX	MEM	WB

---

Execution incorrect because ...

... **sub** reads **r1** before **add** writes (or even finishes computing) **r1**, ...

... **and** reads **r1** before **add** writes **r1**, and ...

... **xor** reads **r4** before **sub** writes **r4**.

Incorrect execution due to...

... *dependencies* in program...

... **and hazards** in hardware (pipeline).

Incorrect execution above is the “fault” of the hardware...

... because the ISA does not forbid dependencies.

*Dependency:*

A relationship between two instructions ...

... indicating that their execution should be (or appear to be) in program order.

*Hazard:*

A potential execution problem in an implementation due to overlapping instruction execution.

There are several kinds of dependencies and hazards.

For each kind of dependence there is a corresponding kind of hazard.

*Dependency:*

A relationship between two instructions ...

... indicating that their execution should be (or appear to be) in program order.

If there is a dependency between instruction *A* and instruction *B* ...

... and *B* follows *A* in program order ...

... then *B* is said to be *dependent* on *A*.

If *B* is dependent on *A* then *A* should appear to execute before *B*.

Dependency Types:

- *True, Data, or Flow Dependence* (Three different terms used for the same concept.)
- *Name Dependence*
- *Control Dependence*

*Data Dependence:* (a.k.a., *True* and *Flow* Dependence)

A dependence between two instructions ...

... indicating data needed by the second is produced by the first.

Example:

---

```
add r1, r2, r3
sub r4, r1, r5
and r6, r4, r7
```

---

The `sub` is dependent on `add` (via `r1`).

The `and` is dependent on `sub` (via `r4`).

The `and` is dependent `add` (via `sub`).

Execution may be incorrect if ...

... a program having a data dependence ...

... is run on a processor having an uncorrected RAW hazard.

There are two kinds: *antidependence* and *output dependence*.

*Antidependence:*

A dependence between two instructions ...

... indicating a value written by the second ...

... that the first instruction reads.

Antidependence Example

---

```
add r1, r2, r3
sub r2, r4, r5
```

---

`sub` is antidependent on the `add`.

Execution may be incorrect if ...

... a program having an antidependence ...

... is run on a processor having an uncorrected WAR hazard.

*Output Dependence:*

A dependence between two instructions ...

... indicating that both instructions write the same location ...

... (register or memory address).

Output Dependence Example

---

```
add r1, r2, r3
sub r1, r4, r5
```

---

The `sub` is output dependent on `add`.

Execution may be incorrect if ...

... a program having an output dependence ...

... is run on a processor having an uncorrected WAW hazard.

*Control Dependence:*

A dependence between a branch instruction and a second instruction ...

... indicating that whether the second instruction executes ...

... depends on the outcome of the branch.

---

```
beq $1, $0 SKIP # Delayed branch
nop
add $2, $3, $4
SKIP:
sub $5, $6, $7
```

---

The `add` is control dependent on the `beq`.

The `sub` is not control dependent on the `beq`.

*Hazard:*

A potential execution problem in an implementation due to overlapping instruction execution.

*Interlock:*

Hardware that avoids hazards by stalling certain instructions when necessary.

## Hazard Types:

*Structural Hazard:*

Needed resource currently busy.

*Data Hazard:*

Needed value not yet available or overwritten.

*Control Hazard:*

Needed instruction not yet available or wrong instruction executing.

Identified by acronym indicating correct operation.

- *RAW*: Read after write, akin to data dependency.
- *WAR*: Write after read, akin to anti dependency.
- *WAW*: Write after write, akin to output dependency.

DLX and MIPS implementations above only subject to RAW hazards.

RAR not a hazard since read order irrelevant (without an intervening write).

When threatened by a hazard:

- *Stall* (Pause a part of the pipeline.)  
Stalling avoids overlap that would cause error.

This does slow things down.

- Add hardware to avoid the hazards.  
Details of hardware depend on hazard and pipeline.

Several will be covered.

Cause: two instructions simultaneously need one resource.

Solutions:

Stall.

Duplicate resource.

Pipelines in this section **do not** have structural hazards.

Covered in more detail with floating-point instructions.

HP Chapter-3 DLX and MIPS Subject to RAW Hazards.

Consider the following **incorrect execution** of code containing data dependencies.

! Cycle	0	1	2	3	4	5	6	7
add r1, r2, r3	IF	ID	EX	MEM	WB			
sub r4, r1, r5		IF	ID	EX	MEM	WB		
and r6, r1, r8			IF	ID	EX	MEM	WB	
xor r9, r4, r11				IF	ID	EX	MEM	WB

Execution incorrect because ...

... **sub** reads **r1** before **add** writes (or even finishes computing) **r1**, ...

... **and** reads **r1** before **add** writes **r1**, and ...

... **xor** reads **r4** before **sub** writes **r4**.

Problem fixed by *stalling* the pipeline.

*Stall:*

To pause execution in a pipeline from IF up to a certain stage.

With stalls, code can execute correctly:

For code on previous slide, stall until data in register.

! Cycle	0	1	2	3	4	5	6	7	8	9	10
add r1, r2, r3	IF	ID	EX	MEM	WB						
sub r4, r1, r5		IF	ID	----->	EX	MEM	WB				
and r6, r1, r8			IF	----->	ID	EX	MEM	WB			
xor r9, r4, r11					IF	ID	->	EX	MEM	WB	

Arrow shows that instructions stalled.

Stall creates a *bubble*, segments without valid instructions, in the pipeline.

With bubbles present, CPI is greater than its ideal value of 1.

Stall Implementation

Stall implemented by asserting a *hold* signal ...

... which inserts a **nop** (or equivalent) after the stalling instruction and ...

... disables clocking of pipeline latches before the stalling instruction.

! Cycle	0	1	2	3	4	5	6	7	8	9	10
add r1, r2, r3	IF	ID	EX	MEM	WB						
sub r4, r1, r5		IF	ID	----->	EX	MEM	WB				
and r6, r1, r8			IF	----->	ID	EX	MEM	WB			
xor r9, r4, r11					IF	ID	->	EX	MEM	WB	

During cycle 3, a **nop** is in EX.

During cycle 4, a **nop** is in EX and MEM.

The two adjacent **nops** are called a *bubble* ...

... they move through the pipeline with the other instructions.

A third **nop** is in EX in cycle 7.

Some stalls are avoidable.

Consider again:

! Cycle	0	1	2	3	4	5	6	7	8	9	10
add r1, r2, r3	IF	ID	EX	MEM	WB						
sub r4, r1, r5		IF	ID	EX	MEM	WB					
and r6, r1, r8			IF	ID	EX	MEM	WB				
xor r9, r4, r11				IF	ID	EX	MEM	WB			

Note that the new value of **r1** needed by **sub** ...

... has been computed at the end of cycle 2 ...

... and isn't really needed until the beginning of the *next* cycle, 3.

Execution was incorrect because the value had to go around the pipeline to ID.

Why not provide a shortcut?

Why not call a shortcut a *bypass* or *forwarding* path?

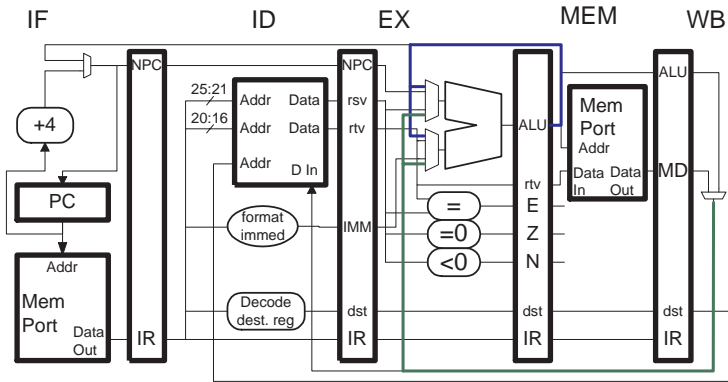
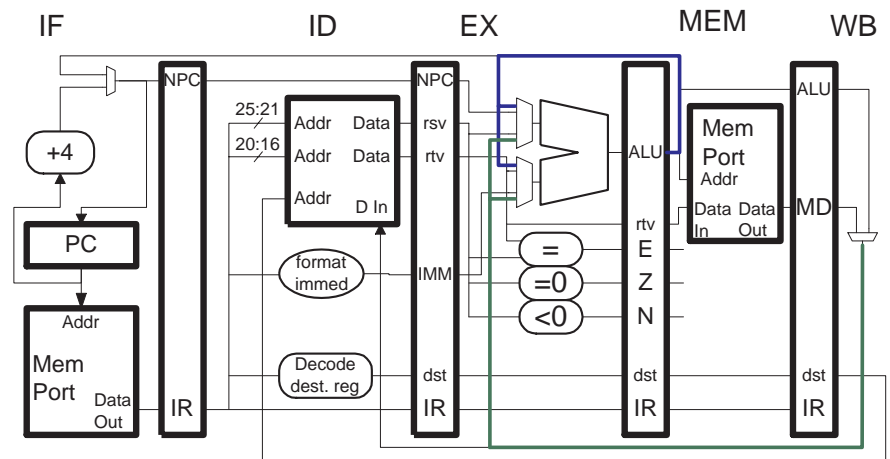
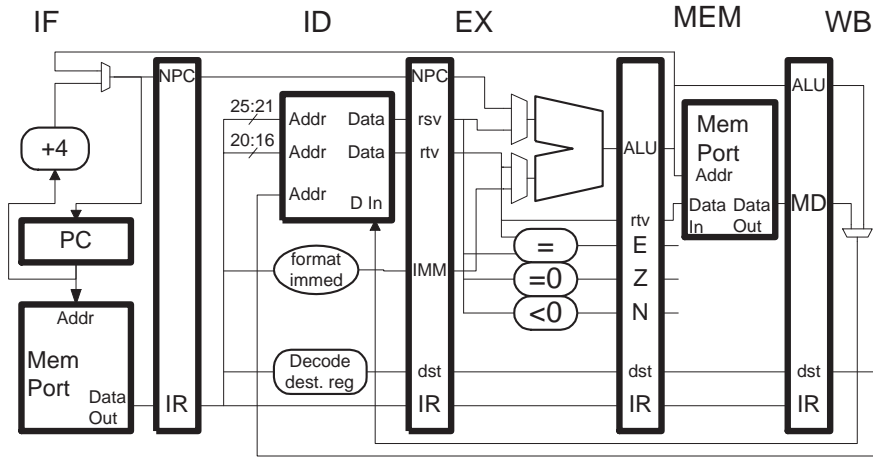

! Cycle	0	1	2	3	4	5	6	7	8	9	10
add r1, r2, r3	IF	ID	EX	MEM	WB						
sub r4, r1, r5		IF	ID	EX	MEM	WB					
and r6, r1, r8			IF	ID	EX	MEM	WB				
xor r9, r4, r11				IF	ID	EX	MEM	WB			

It works!

Not all stalls are avoidable.

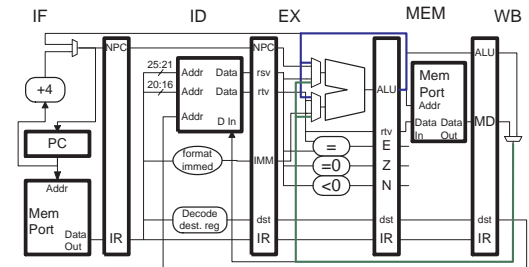

! Cycle	0	1	2	3	4	5	6	7	8	9	10
lw r1, 0(r2)	IF	ID	EX	MEM	WB						
add r1, r1, r4		IF	ID	->	EX	MEM	WB				
sw 4(r2), r1			IF	->	ID	----->	EX	MEM	WB		
addi r2, r2, 8				IF	----->	ID	EX	MEM	WB		

Stall due to lw could not be avoided (data not available in cycle 3).

Stall in cycles 5 and 6 could be avoided with a new forwarding path.

Start with logic for `rd`, show path of Mux logic.

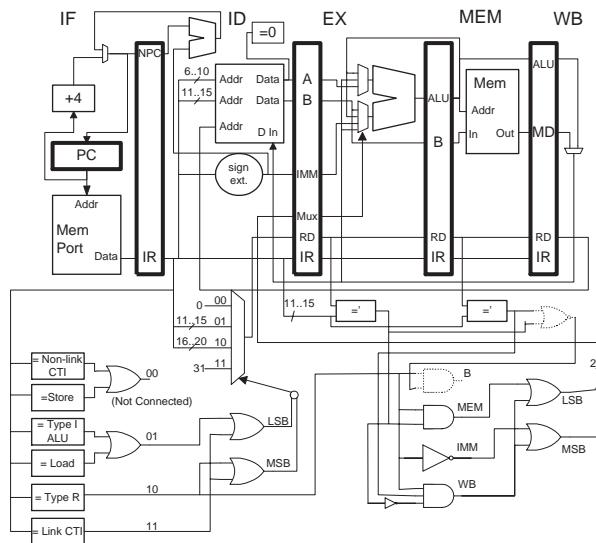
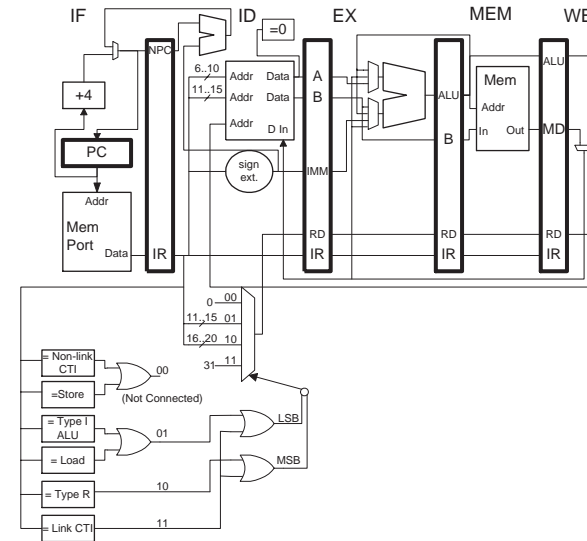
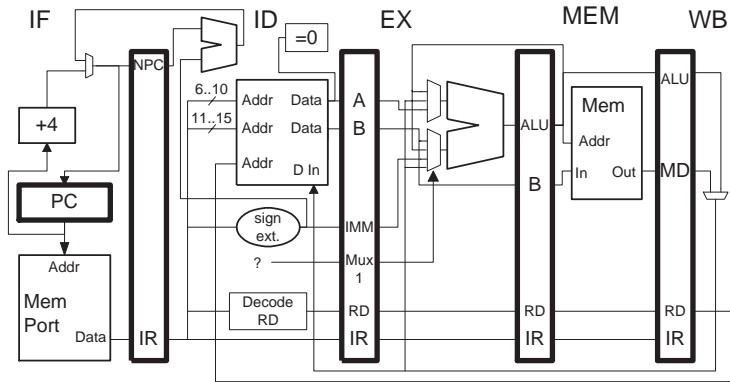

Control logic not minimized (for clarity).

Control Logic Generating `ID/EX.RD`.

Present in previous implementations, just not shown.

Determines which register gets written based on instruction.

Instruction categories used in boxes such as `= Load` (some instructions omitted):

`= Non-link CTI`: branches and jumps except linking jumps (`jal` and `jalr`).

`= Store`: All store instructions.

`= Type I ALU`: All Type I ALU instructions.

`= Load`: All load instructions.

`= Type R`: All Type R instructions.

`= Link CTI`: `jal` and `jalr`.

Logic Generating ID/EX.MUX.

$\boxed{=}$  box determines if two register numbers are equal.

Register number zero is not equal register zero, nor any other register.

(The bypassed zero value might not be zero.)

Cause: on **taken** CTI several wrong instructions fetched.

Consider:

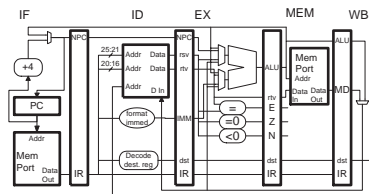
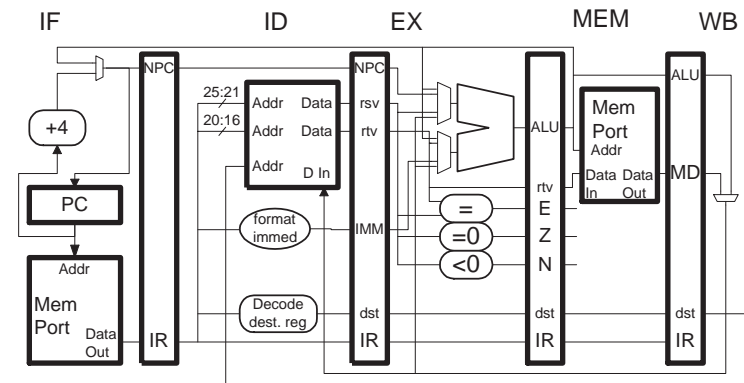

Example of **incorrect** execution

!I Adr	Cycle	0	1	2	3	4	5	6	7	8
0x100 bgtz r4, TARGET	TARGET	IF	ID	EX	MEM	WB				
0x104 sub r4, r2, r5			IF	ID	EX	MEM	WB			
0x108 sw 0(r2), r1				IF	ID	EX	MEM	WB		
0x10c and r6, r1, r8				IF	ID	EX	MEM	WB		
0x110 or r12, r13, r14										
...										
TARGET: ! TARGET = 0x200										
0x200 xor r9, r4, r11					IF	ID	EX	MEM	WB	

Branch is taken yet two instructions past delay slot (**sub**) complete execution.

Branch target finally fetched in cycle 4.

Problem: Two instructions following delay slot.

Handling Instructions Following a Taken Branch Delay Slot

Option 1: Don't fetch them.

Possible (with pipelining) because ...

... fetch starts (**sw** in cycle 2) ...

... after branch decoded.

(Would be impossible ...

... for non-delayed branch.)

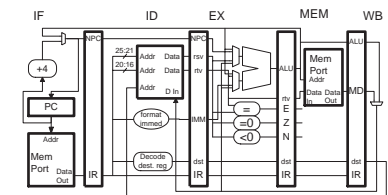

!I Adr	Cycle	0	1	2	3	4	5	6	7	8
0x100 bgtz r4, TARGET	TARGET	IF	ID	EX	MEM	WB				
0x104 sub r4, r2, r5			IF	ID	EX	MEM	WB			
0x108 sw 0(r2), r1				IF	ID	EX	MEM	WB		
0x10c and r6, r1, r8				IF	ID	EX	MEM	WB		
0x110 or r12, r13, r14										
...										
TARGET: ! TARGET = 0x200										
0x200 xor r9, r4, r11					IF	ID	EX	MEM	WB	

## Handling Instructions Following a Taken Branch

Option 2: Fetch them, but squash (stop) them in a later stage.

This will work if instructions squashed ...

... *before* modifying architecturally visible storage (registers and memory).

Memory modified in MEM stage and registers modified in WB stage ...

... so instructions must be stopped before beginning of MEM stage.

Can we do it? Depends depends where branch instruction is.

In example, need to squash `sw` before cycle 5.

During cycle 3 `bgtz` in MEM ...

... it has been decoded and the branch condition is available ...

... so we know whether the branch is taken ...

... so `sw` can easily be squashed before cycle 5.

Option 2 will be used.

## Instruction Squashing

### *In-Flight Instruction*::

An instruction in the execution pipeline.

Later in the semester a more specific definition will be used.

### *Squashing*:: [an instruction]

preventing an in-flight instruction ...

... from writing registers, memory or any other visible storage.

Squashing also called: *nulling*, *abandoning*, and *cancelling*..

Like an insect, a squashed instruction is still there (in most cases) but can do no harm.

## Squashing Instruction in Example DLX Implementation

Two ways to squash.

- Prevent it from writing architecturally visible storage.

Replace destination register control bits with zero. (Writing zero doesn't change anything.)

Set memory control bits (not shown so far) for no operation.

- Change Operation to `nop`.

Would require changing many control bits.

Squashing shown that way here for brevity.

Illustrated by placing a `nop` in `IR`.

Why not replace squashed instructions with target instructions?

Because there is no straightforward and inexpensive way ...

... to get the instructions *where and when* they are needed.

(Curvysideways and expensive techniques covered in Chapter 4.)

MIPS implementation used so far.

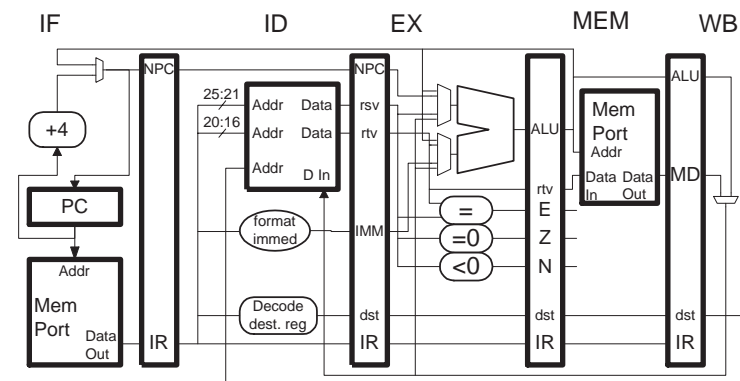

Example of correct execution

!I	Adr	Cycle	0	1	2	3	4	5	6	7	8
0x100	bgtz r4, TARGET	IF	ID	EX	MEM	WB					
0x104	sub r4, r2, r5		IF	ID	EX	MEM	WB				
0x108	sw 0(r2), r1			IF	IDx						
0x10c	and r6, r1, r8				IFx						
0x110	or r12, r13, r14										
...											
TARGET: !	TARGET = 0x200										
0x200	xor r9, r4, r11			IF	ID	EX	MEM	WB			

Branch outcome known at end of cycle 2 ...

... wait for cycle 3 when doomed instructions (**sw** and **and**) in flight ...

... and squash them so in cycle 4 they act like **nops**.

Two cycles (1, 2, and 3), are lost.

Two cycles called a *branch penalty*.

Two cycles is alot of cycles, is there something we can do?

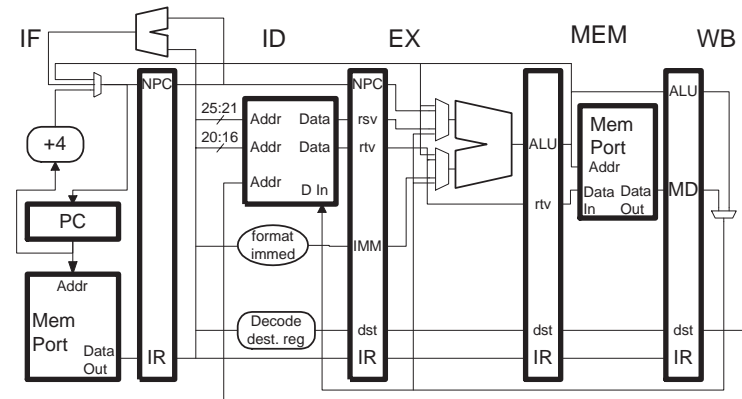

Compute branch target address in ID stage.

Compute branch target and condition in ID stage.

Workable because register values not needed to compute branch address and ...

... branch condition can be computed quickly.

Now how fast will code run?

!I	Adr	Cycle	0	1	2	3	4	5	6	7	8
0x100	bgtz r4, TARGET	IF	ID	EX	MEM	WB					
0x104	sub r4, r2, r5		IF	ID	EX	MEM	WB				
0x108	sw 0(r2), r1			IF	ID	EX	MEM	WB			
0x10c	and r6, r1, r8				IF	ID	EX	MEM	WB		
0x110	or r12, r13, r14										
...											
TARGET: !	TARGET = 0x200										
0x200	xor r9, r4, r11			IF	ID	EX	MEM	WB			

No penalty, not a cycle wasted!!

